



**Autoracker and Remote Controller**

Pages 6 and 7.

**Air  
Circuit  
Breakers**



*TemPower*





[Terasaki is the world leader for circuit breakers in switchgear in the marine market]

Terasaki supply circuit breakers which protect people and equipment from electrical faults. Safety and protection are the prime purposes of our products.

We supply products to switchboard builders, shipbuilders and equipment manufacturers. We are global market leaders for switchgear in the marine market. Terasaki have worldwide export experience and the necessary professional skills to support your business.



[Telehouse Data Centre, London. 199 TemPower 2 ACBs, 423 TemBreak 2 MCCBs.]



## Upgrade for AGR-31B Protection Relay

# MORE MONITORING FEATURES



The new AGR-31B “H” ensures optimum monitoring and performance.

### Safe Mode

A safe mode can be enabled during switchboard maintenance. Two independent INST thresholds can be saved in on-board memory. The user can toggle INST settings quickly via the LCD menu or over the data communication link. A lower INST threshold will reduce the incident arc energy. Settings can be quickly returned to normal after maintenance to provide optimum performance.

### Accurate Setting

Overload protection settings can be matched exactly to the circuit needs. LTD current threshold settings can be fine-tuned to the nearest Ampere.

### New Alarms

Under/over-voltage; under/over-frequency. Take action automatically if these parameters go outside your acceptable limits. Volt-free output contacts included. **AVAILABLE AS AN OPTIONAL EXTRA FEATURE OF AGR-31B...H.**

### Harmonics

Harmonic current measurement. Identify loads causing harmonic pollution, optimise harmonic filtering and ultimately save money with this new feature. Monitors individual harmonic currents per phase at each harmonic order. **INCLUDED AS STANDARD WITH AGR-31B...H.**

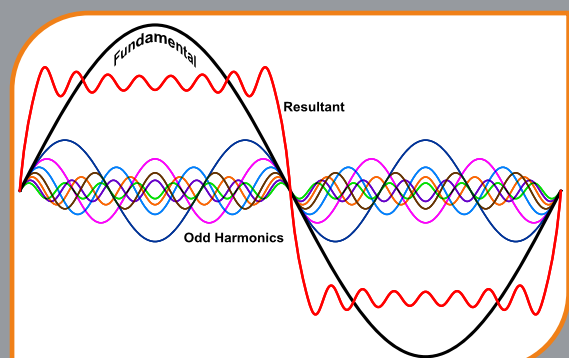



## Tempower 2 ACBs for 800V and 1000V AC



High AC voltages are used to minimise cable costs for installations where long cable runs are necessary.

Terasaki supply ACBs for large solar farms, mines and railways. The latest additions to our range are the AR316H-V8, AR325H-V8 & AR332-V8 which can all interrupt 30kA at 800VAC.

## DC ACBs

Terasaki now offer a new broad range of dedicated DC air circuit breakers and moulded case circuit breakers. The range of Terasaki DC circuit breakers are ideally suited for all types of industries, information technology and communication sectors where highly reliable sources of electric power are required.

DC ACBs are suitable for 600V and 800V DC applications. [Standard AR ACBs (S&H types) are only suitable for 250V DC applications].





## Condition Based Maintenance



### 3C BENEFITS

- **LOW INVESTMENT** [system is integrated with circuit breakers]
- **FAST INSTALLATION** [breakers are supplied with sensors already fitted]
- **EASY UPGRADE** [the 3C system can be retrofitted to existing installations]
- **FREE EXTENDED WARRANTY ON NEW CIRCUIT BREAKERS** [when 3C overheating protection is included with the order]

### Contact temperature monitoring function (optional)

This function monitors the temperature of the ACBs main contacts. An alarm indicates when the temperature exceeds the withstand temperature of the contacts. Continuous monitoring of the contact temperature provides valuable input for preventative and predictive maintenance programmes.



### 3C overheating protection is new and unique!

It is only available from Terasaki for TemPower 2 ACBs and TemBreak 2 MCCBs.





## Tempower 2 Autoracker

Terasaki are now supplying the TemPower 2 ACB Autoracker and Remote Controller for use in factories, process plants and mining.



### Here's how to make switchgear operations safer:

**1. a. Autoracking for new or existing switchboards with TemPower 2 ACBs:**

The Autoracker can be used with any new or existing TemPower 2 ACB. Simply contact us to order the Autoracker kit which we will supply in a rugged trolley case with tools included.

**b. Autoracking for ACBs other than TemPower 2:**

We can easily retrofit other brands to TemPower 2 ACBs. Ask us about retrofit with Autoracker.

**2. a. Remote Controller for new TemPower 2 ACBs:**

Ask us to include a remote controller as an optional accessory at the time of your order.

**b. Remote controller for installed TemPower 2 ACBs:**

Our technicians will come to site and rewire the ACBs for remote control. Ask us about rewire for remote control.



## Tempower 2 Remote Controller



The TemPower 2 ACB remote controller opens and closes the ACB at a safe distance, this means you can:

- **Remove operators from risk**
- **Comply with Health and Safety Guidance\***

The remote controller is quick to install and easy to use:

1. connect the pendant to the “umbilical” socket on the front cover of the ACB;
2. retreat outside the arc flash boundary;
3. Use the pushbuttons to open and close the ACB.



Clamp the autoracker to the ACB



Plug in the umbilical cable



Retreat to a safe distance with the pendant controller.



# TERASAKI PROFILE



Mr. Taizo Terasaki  
President

“We want to meet the needs of more customers around the world in our circuit breaker and lifecycle service businesses.”

Mr. Taizo Terasaki, President



Mr. Yasuhiko Terasaki  
Late chairman of the company



Mr. Yasutaro Terasaki  
Founder of the company

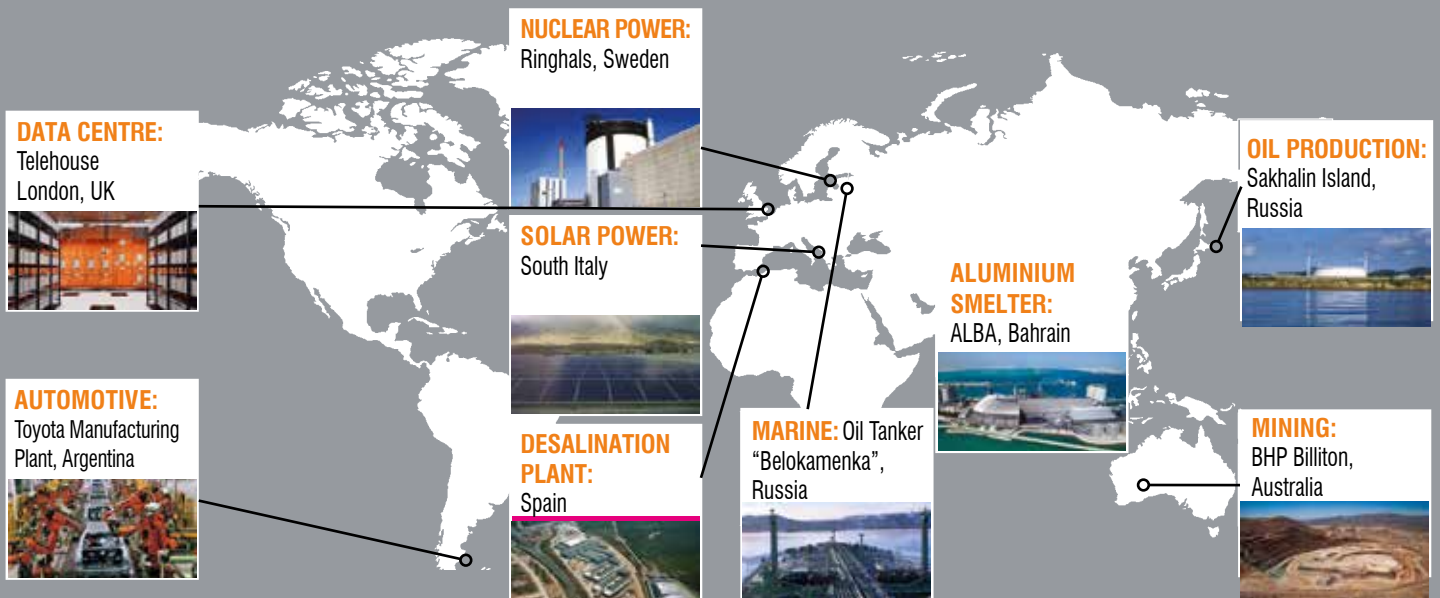

## R&D

We are meeting the needs of customers with a complete system of development, design and manufacture based on the know-how we have accumulated with electrics, electronics and control over the decades since our founding.

We have DEKRA (formerly KEMA)-approved test systems and two generators in house to carry out the necessary development tests.

Terasaki realises optimised products through 3D CAD, software development, mould and sheet metal design, structural design and resin flow analysis.



## CAPABILITIES

### Safety & Reliability

High MTBF; Low MTTR; temperature monitoring, double control circuits

### Approvals

ISO 9001; ISO 14001; OHSAS 18001; Lloyds; BV; GL; GOST; SABS; DEKRA (KEMA); ASTA; IEC 60947-2; IEC 61439; IEC 60898

### Asset Management

Retrofits; Preventative Maintenance; Lifecycle Management

Special Protection Solutions

DC; PV; UPS; 1000V AC; Integrated residual protection; 100kA and above

## PRODUCTS & SERVICES



Air Circuit Breakers



Moulded Case Circuit Breakers



Din Modular Protection



Contactors



Automatic Transfer Controller



Monitoring & Communication



Asset Management



Retrofit



## 5 Reasons to use TemPower 2 ACBs



### 1. Arc flash reduction: Safe mode

To minimise the damage that an arc flash can cause to a switchboard, the incoming circuit breaker must be set to detect and clear the arc fault within an optimum timeframe. Safe mode works by automatically implementing a temporary protection setting 'maintenance mode' within the incoming ACB before people can enter the switch room.

### 2. Arc flash reduction: Remote switching

The TemPower 2 ACB can be configured for remote switching during maintenance. This system uses the principle that "distance is safety" and removes the operator from the proximity of the breaker being operated.

### 3. Fast interruption by unique "Double Break" system\*

The unique "DoubleBreak" main contact system ensures extremely fast interruption of short circuit currents and substantially reduces main contact wear. The internally symmetrical "DoubleBreak" structure means the moving contact is isolated from the supply voltage even when the ACB is reverse connected. TemPower 2 ACBs up to 4000A use DoubleBreak technology.

### 4. Easy Maintenance

The unique design of TemPower 2 incorporates its isolating clusters and main contacts on the ACB body. The main contacts and isolating clusters may be maintained without having to isolate the switchboard.

### 5. Replacement of the main contacts\*

The fixed and moving contacts can easily be replaced in the field, thus prolonging the life on the circuit breaker. Changing each pole takes around 15 minutes.

\*Not available on AR6

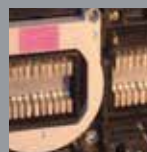

### CUSTOMER ENDORSEMENT

"The performance of Terasaki's ACBs was proven on site when a main busbar failed in one of the switchrooms. The ACB was reclosed on the short-circuit fault twice during fault diagnosis and is still in operation following a service by Terasaki."

Andy Oswald, BAA  
(Airport Operating Company, UK)



Heathrow Airport Terminal 5



Understanding and employing TemPower 2 special features .....	1
Choosing a TemPower 2 ACB .....	2
Choosing accessories and protection relay .....	3
Installing the TemPower 2 ACB .....	4
Technical data .....	5
Useful related products and services .....	6
TemPower 2 Order Form .....	Page 95-96



# Understanding and employing TemPower 2 special features

## SECTION

## 1

- ▶ **Protection Features** ..... 14-17
- ▶ **Performance Features** ..... 18
- ▶ **ACB Accessory Overview** ..... 19
- ▶ **Appearance** ..... 20



# Protection Features

1



AGR-11B

### Protection Functions Dial Adjustment

- L – Long Time
- S – Short Time
- I – Instantaneous

### Optional Protection Functions

- Unrestricted Ground Fault
- Neutral Protection

### Manual Reset

- (Optional - AGR-11BL-AS)
- AGR-11BL-GS)

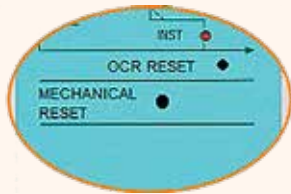

AGR-21B

### Protection Functions LCD Ammeter

- L – Long Time
- S – Short Time
- I – Instantaneous
- Pre-Trip (load shedding)
- Fault Indication Contacts

### Optional Protection Functions

- Ground Fault (Unrestricted or Restricted)
- Neutral Protection
- Communication
- Phase Rotation Protection
- Generator Protection Curves
- IDMT Protection Curves
- Field Test



AGR-31B

### Protection Functions Back-Lit Energy Analyser

- L – Long Time
- S – Short Time
- I – Instantaneous
- Pre-Trip (load shedding)
- Fault Indication Contacts

### Optional Protection Functions

- Ground Fault (Unrestricted or Restricted)
- Neutral Protection
- Reverse Power
- Zone Interlocking
- 3C Overheating Protection
- Communication
- Phase Rotation Protection
- Generator Protection Curves
- IDMT Protection Curves
- Field Test
- Under/over Frequency
- Under/over Voltage Alarm
- Harmonic Monitoring
- Event history
- Dual settings capability



Non-Automatic (switch-disconnector) versions without protection are available in every frame size.



## Protection Features

### Overload Protection

Adjustable from 40-100% of rated current. Thermal memory is available on the AGR21B/31B.

### Two channel pre-trip alarm function (optional)

This function can be used to monitor critical circuits. For example, the function can be set so that when a pre-trip alarm is activated, non-essential loads can be switched off. This feature is only available on AGR22B/31B protection relay models with a generator “S” characteristic.

### Negative Sequence Current Protection Function

In 3-phase, 4 wire systems that contain harmonic distortion, large currents may flow through the neutral conductor. The N-phase protection function prevents the neutral conductor from sustaining damage or burn-out due to these large currents. **(ANSI-46).**

### Ground fault trip function

This function eliminates external relays to provide a ground fault protection to TN-C or TN-S power distribution systems on the load side. Ground fault protection on the line side (restricted earth fault) is also available as an option.

### Earth leakage trip function

Used in conjunction with Zero phase Current Transformer (ZCT), this function provides protection against leakage to earth of very small levels of current. Trip or alarm indication, and contact output is available to enhance the level of system protection.

### Phase rotation protection function

This function detects the negative-phase current occurring due to reverse phase or phase loss and prevents burnout of a motor or damage to equipment.

### Reverse power trip function (S-characteristic)

This feature provides additional protection when paralleling generators. The AGR22B/31B protection relay for generator protection with the reverse power trip function, negates the need for installation and wiring in an external reverse power relay. This feature is available using an AGR protection relay with a generator “S” type characteristic only. **(ANSI-32R)**

### Advanced LCD display, Protection Relay

The AGR-31B protection relay comes standard with the backlit LCD display. It can monitor and indicate phase currents, voltages, power, energy, power factor, frequency and more. For features refer to page 40. The backlit LCD is optional for AGR-21B and AGR-22B.

### Remote Communications Protocols (optional)

Data communications via Modbus, an open network, are supported.

#### Energy Measurement

I, V, kW, MWh, kVar, cos $\phi$ , frequency, harmonics

#### Intelligent Fault Analysis

Status, fault type, fault size, tripping time, fault history

#### Maintenance Information

Trip circuit supervision, contact temperature monitoring. For details please refer to page 14.

For other protocols please contact Terasaki.

### 3C Overheating Protection (optional)

This function monitors the temperature of the ACBs main contacts. An alarm indicates when the temperature exceeds the withstand temperature of the contacts. Continuous monitoring of the contact temperature provides valuable input for preventative and predictive maintenance programmes. This option can be used with communication.

### New Features (more details on page 3)

Two independent INST thresholds for quick toggling of safe mode.

Fine adjustment of overload current LTD threshold to the nearest Ampere.

Harmonic current measurement.

Under/over voltage protection (ANSI 27A/810) (optional).

Under/over frequency protection (ANSI 81U/59A)(optional).



# Protection Features

## Communications facility added to TemPower 2

1

TemPower 2 is equipped with an optional communication interface unit that allows data exchange with a host PC via a Modbus open network. Data communication includes measurements, fault log, maintenance information. ON/OFF status, settings and control (ON/OFF/RESET) signals.

### Fault log

Cause	Whichever trip functions, LTD, STD, INST or GF is activated is then transmitted
Fault current	The fault current at which the breaker tripped open is transmitted.
Trip pick-up time	The trip pick-up time is transmitted.

### Maintenance Information

Tripping circuit monitoring	The tripping coil is always monitored for disconnection. If the breaker is not open within approx. 300 ms of a trip signal delivered from the OCR, an alarm signal is generated.
-----------------------------	--

### Data Measurement

Phase current	Phase current $I_1, I_2, I_3, I_N, I_g$ and max current $I_{max}$ are measured and transmitted. Harmonic currents.
Line-to-line voltage	$V_{12}, V_{23}$ , and $V_{31}$ are measured.
Demand active power	Active power demand (over time) and historical max. power are recorded.
Accumulated power	Accumulated power is measured.
Power factor	Circuit power factor is measured.
Frequency	Frequency is measured.

**Note:** Above is for type AGR-31 Protection relay.  
Type AGR-21 and AGR-22 measure only phase current.

### Network Interface I/O specifications

Item	Modbus
Transmission standard	RS-485
Transmission method	Two-wire half-duplex
Topology	Multi-drop bus
Transmission rate	19.2 kbps max
Transmission distance	1.2 km max (at 19.2 kbps)
Data format	Modbus-RTU or ASCII
Max number of nodes	1 - 31

### On-screen PC monitor

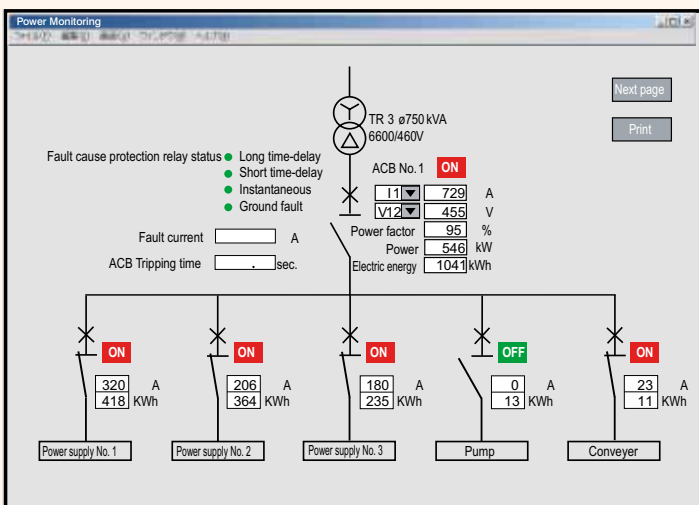

### Communication network

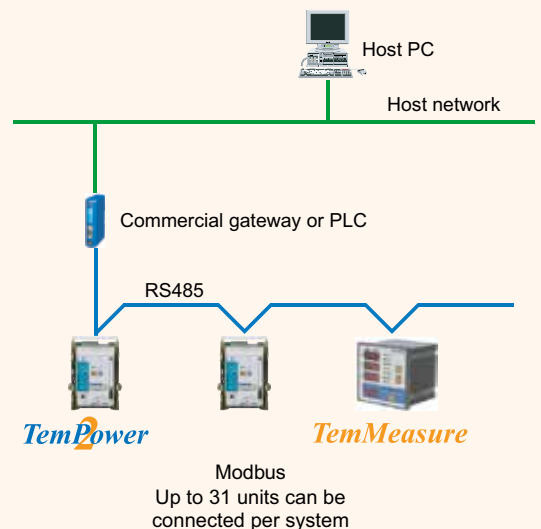



## Protection Features

### Optimum protective co-ordination

**Why use a separate panel mounted protection relay when you can have all the benefits of I.D.M.T. protection integral to the ACB?**

**TemPower 2** is available with a choice of flexible protection curves to assist in selectivity applications.

**S.I. Standard Inverse**

**V.I. Very Inverse**

**E.I. Extremely Inverse**

All these curves are user definable and comply with IEC 60255-3. Standard transformer and generator protection characteristics are also available.

AGR-L Industrial & transformer protection

AGR-S Generator protection

AGR-R Characteristics to IEC 60255-3

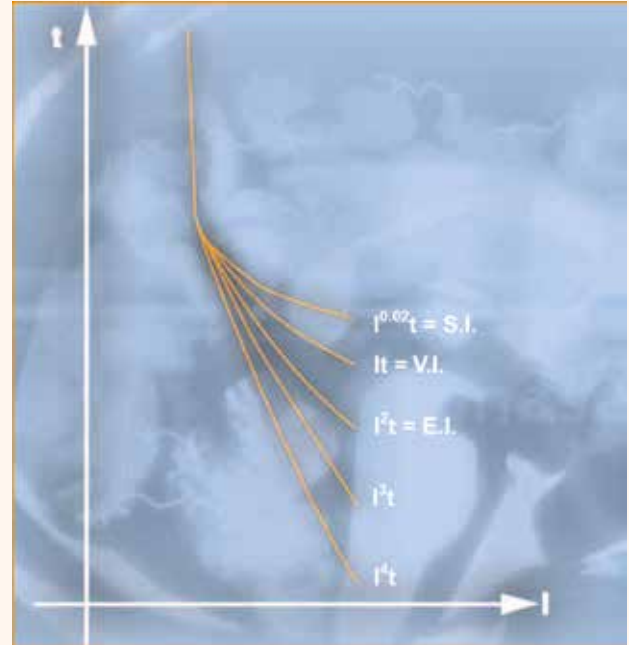

Inverse Definite Minimum Time (I.D.M.T.)

### Zone interlocking

In conventional discrimination systems, short time delays are used to allow a short-circuit current to be tripped by the circuit breaker nearest the fault. The disadvantage of this type of system is during a fault considerable thermal and mechanical stresses are placed on the entire system. With the **TemPower 2** Z Interlock system the breaker nearest the fault will trip first, irrespective of the short time delay setting or ground fault trip time delay setting.

#### Example of operation:

If a fault occurs in Zone 2, only AR Z Interlock 'A' will sense any fault current fault, a no fault signal will be sent by AR Z Interlock 'B' and 'C', consequently AR Z interlock 'A' trips the ACB immediately, overriding its short time delay.

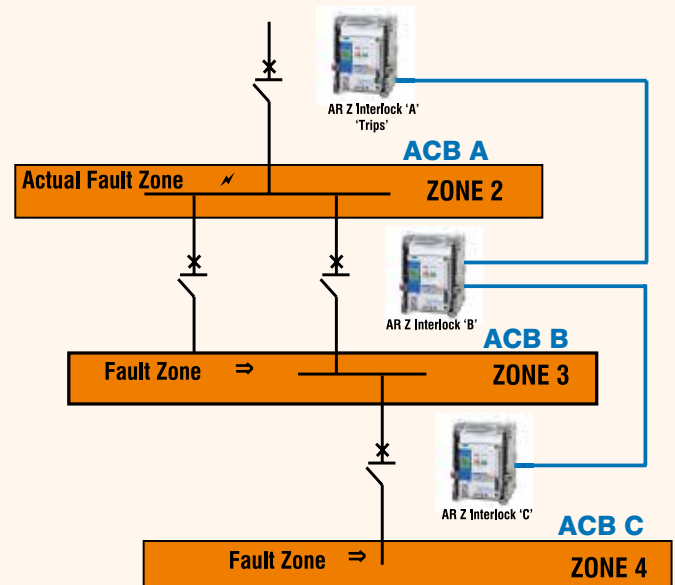

Example of AR Zone Interlock Function



## Performance Features

### Double opening and closing coils

1

Double Opening and Closing coils provides extended control system redundancy to an ACB. Double coils allow designers to implement back-up tripping and closing systems. It provides the end user with ultimate reliability on critical UPS circuits connected to critical loads.



### Earthing Device

The unique design of **TemPower 2** ACBs allows for the earthing of either the busbar (line) or the circuit (load) of a low voltage system; thus allowing system flexibility.

Some other manufactures only offer one option either, busbar or circuit earthing.

For full details refer to page 36.



### Protection Relay performance

Ensure that the ACB you specify suffers no loss of performance when tripped by an external protection relay.

The **TemPower 2** ACB suffers no loss in performance when tripped through an external protection relay.

Some competitor's ACBs have reduced breaking performance when an external protection relay is used.

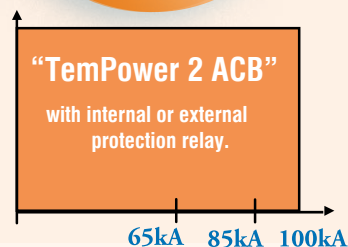
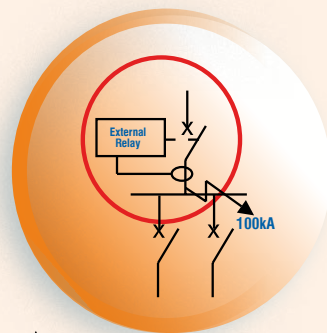



# ACB Accessory Overview

1

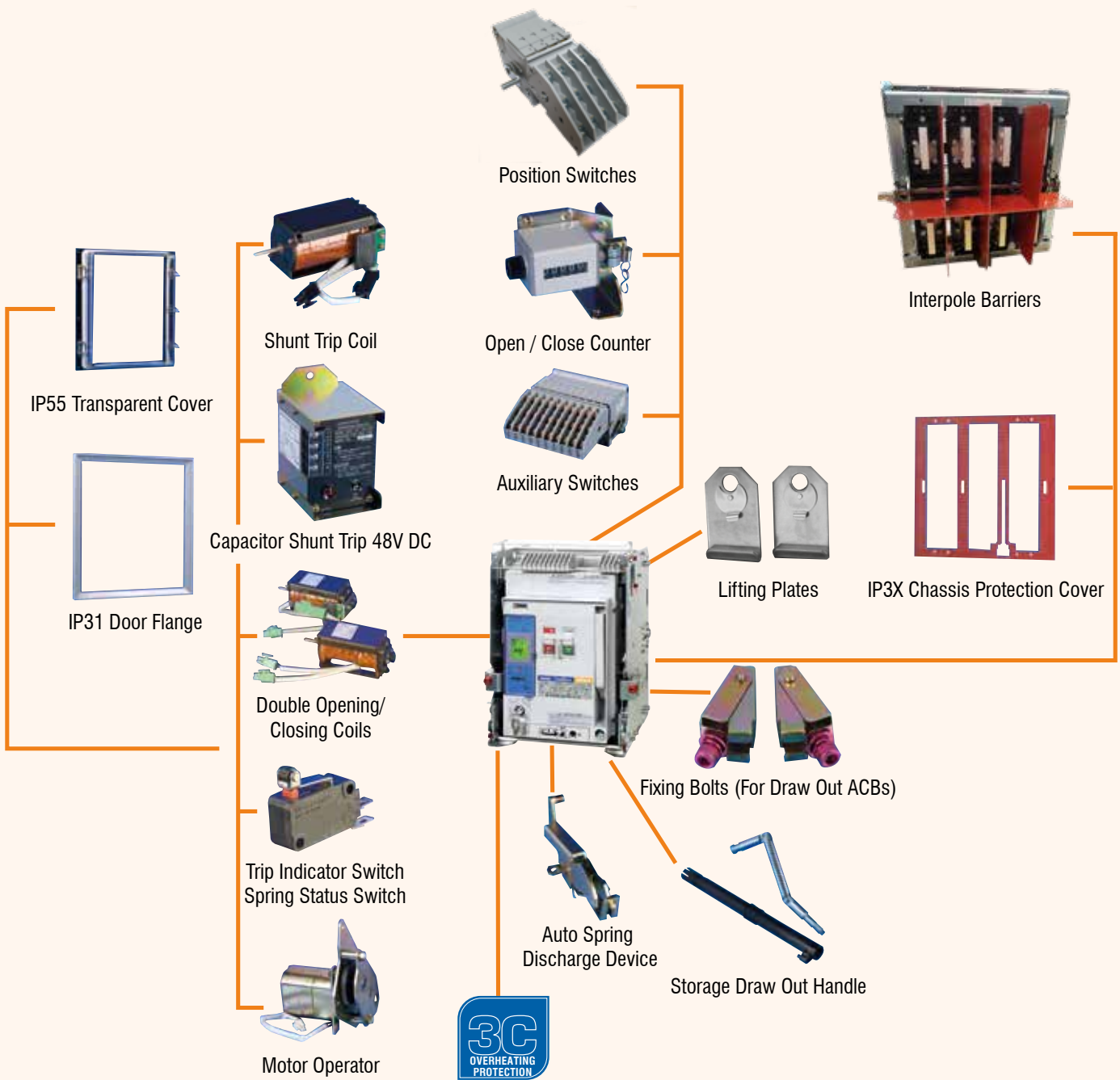

Lifter Loader



Protection Relay Checker



Tropicalisation, Anti-Corrosion, Cold Climate treatments



Test Jumper



Step Down Transformer 440V to 220V



Mechanical Interlock, Key Interlock, Castell Interlock



Shutter Truck



## APPEARANCE

1

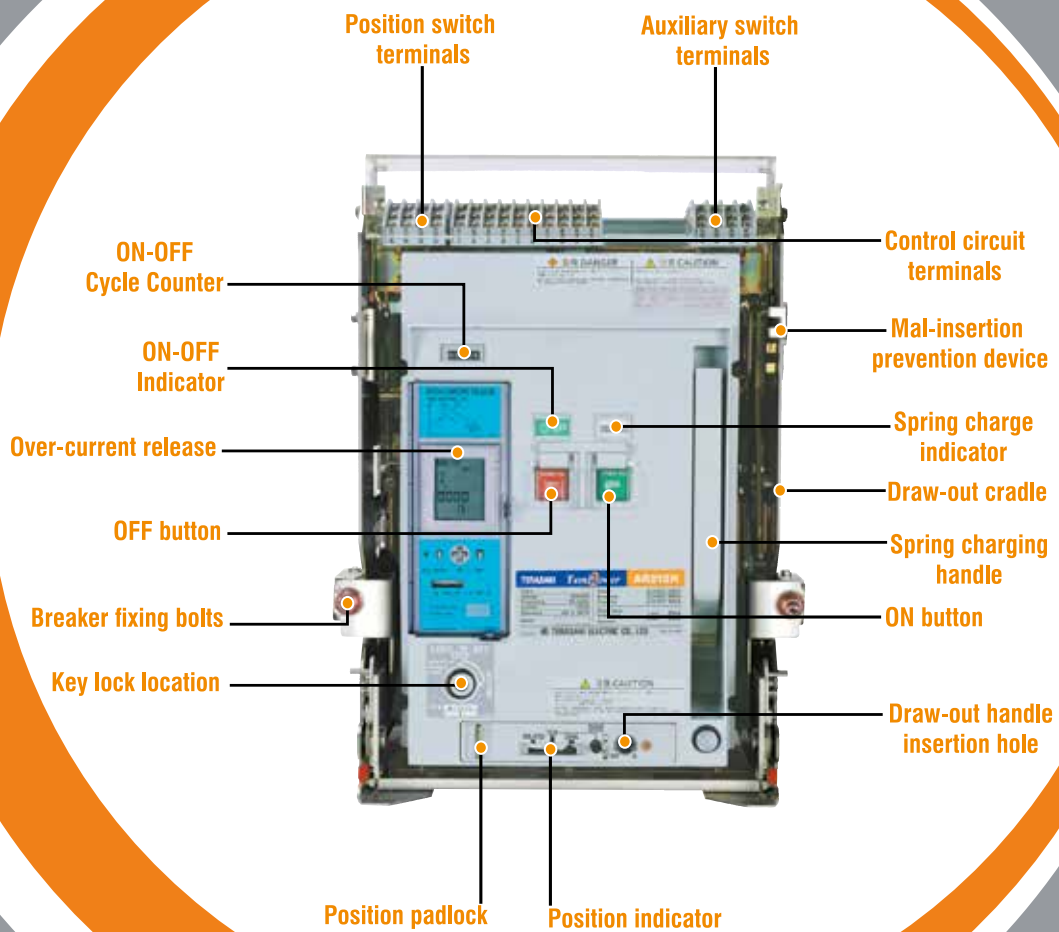

# Choosing a TemPower 2 ACB

## SECTION

## 2

▶	<b>Ratings</b> .....	22-23
▶	<b>Specifications</b> .....	24-25



# Ratings

Series	Standard	Standard	High fault	Standard	High fault	High fault	Standard	High fault
AMPERE RATING(A)	800	1250	1250	1600	1600	1600	2000	2000
TYPE	AR208S	AR212S	AR212H	AR216S	AR216H	AR316H	AR220S	AR220H
RATED CURRENT (max) [ $I_n$ ](A)	800	1250	1250	1600	1600	1600	2000	2000
① ②	JIS ⑫, IEC, EN, AS	NEMA, ANSI	Marine					
NEUTRAL POLE AMPERES FRAME (A)	800	1250	1250	1600	1600	1600	2000	2000
NUMBER OF POLES	3 4	3 4	3 4	3 4	3 4	3 4	3 4	3 4
RATED PRIMARY CURRENT OF OVER-CURRENT RELEASE [ $I_{CT}$ ](A)	200	400	200	400	1600	200	400	2000
RELEASE [ $I_{CT}$ ](A)	400	800	400	800		400	800	
• for general feeder circuit use	800	1000	800	1000		800	1000	
		1250	1000	1250		1250	1250	
			1250	1600		1600	1600	
							2000	
RATED CURRENT OF OVER-CURRENT RELEASE (A)	$100 \leq I_n \leq 200$	$200 \leq I_n \leq 400$	$100 \leq I_n \leq 200$	$200 \leq I_n \leq 400$	$800 \leq I_n \leq 1600$	$100 \leq I_n \leq 200$	$200 \leq I_n \leq 400$	$1000 \leq I_n \leq 2000$
• for generator protection use	$200 < I_n \leq 400$	$400 < I_n \leq 800$	$200 < I_n \leq 400$	$400 < I_n \leq 800$		$200 < I_n \leq 400$	$400 < I_n \leq 800$	
[ $I_n$ ] is generator rated current.	$400 < I_n \leq 800$	$500 < I_n \leq 1000$	$400 < I_n \leq 800$	$500 < I_n \leq 1000$		$400 < I_n \leq 800$	$500 < I_n \leq 1000$	
		$630 < I_n \leq 1250$	$500 < I_n \leq 1000$	$630 < I_n \leq 1250$		$630 < I_n \leq 1250$	$630 < I_n \leq 1250$	
			$630 < I_n \leq 1250$	$800 < I_n \leq 1600$		$800 < I_n \leq 1600$	$800 < I_n \leq 1600$	
							$1000 < I_n \leq 2000$	
AC RATED INSULATION VOLTAGE [ $U_i$ ](V. 50/60Hz)	1000	1000	1000	1000	1000	1000	1000	1000
RATED OPERATIONAL VOLTAGE [ $U_e$ ](V. 50/60Hz)	690	690	690	690	690	690	690	690
AC RATED BREAKING CAP [kA sym rms]/MAKING CAP [kA peak]								
JIS ⑫, IEC, EN, AS	AC 690V	50/105 ⑤	50/105 ⑤	55/121	50/105 ⑤	55/121	85/187	50/105 ⑤
[ $I_{cs} = I_{ca}$ ]	440V	65/143 ⑥	65/143 ⑥	85/187	65/143 ⑥	85/187	100/220	65/143 ⑥
NEMA	AC 635V	42/96.6	42/96.6	42/96.6	42/96.6	42/96.6	50/115	42/96.6
ANSI	508V	50/115	50/115	55/127	50/115	55/127	80/184	50/115
	254V	65/149.5	65/149.5	80/184	65/149.5	80/184	100/230	65/149.5
	DC 250V	40/40	40/40	40/40	40/40	40/40	40/40	40/40
NK ⑨	AC 690V	50/115	50/115	55/128	50/115	55/128	85/201	50/115
	450V	65/153 ⑥	65/153 ⑥	80/186	65/153 ⑥	80/186	100/233	65/153 ⑥
LR, AB, ⑨	AC 690V	50/115	50/115	55/128	50/115	55/128	85/201	50/115
GL, BV	450V	65/153 ⑥	65/153 ⑥	80/186	65/153 ⑥	80/186	100/233	65/153 ⑥
REVERSE CONNECTED		⑮	⑮	⑮	⑮	⑮	⑮	⑮
RATED IMPULSE WITHSTAND VOLTAGE [ $U_{imp}$ ](kV)	12	12	12	12	12	12	12	12
RATED SHORT TIME WITHSTAND CURRENT [ $I_{cw}$ ](kA rms)	1s	65	65	80	65	80	100	65
3s	50	50	55	50	55	75	50	55
LATCHING CURRENT (kA)	65	65	65	65	65	85	65	65
TOTAL BREAKING TIME (s)	0.03	0.03	0.03	0.03	0.03	0.03	0.03	0.03
CLOSING OPERATION TIME								
SPRING CHARGING TIME (s) max.	10	10	10	10	10	10	10	10
CLOSE TIME (s) max.	0.08	0.08	0.08	0.08	0.08	0.08	0.08	0.08
No. of operating cycles								
Mechanical life with maintenance	30000	30000	30000	30000	30000	25000	25000	30000
without maintenance	15000	15000	15000	15000	15000	12000	12000	15000
Electrical life without maintenance AC460V	12000	12000	12000	12000	12000	10000	10000	12000
AC690V	10000	10000	10000	10000	10000	7000	7000	10000
Draw-Out Body (kg)	⑪	45 51	45 51	46 52	46 52	46 52	56 68	46 52
Draw-Out Chassis (kg)	⑪	28 35	28 35	33 42	30 38	33 42	49 57	33 42
Total Draw-Out Weight (kg)	⑪	73 86	73 86	79 94	76 90	79 94	105 125	79 94
Fixed (kg)	⑪	53 59	53 59	54 60	54 60	54 60	80 92	54 60
OUTLINE DIMENSION (mm)								
FIXED TYPE								
		360 445	360 445	360 445	360 445	360 445	466 586	360 445
		460	460	460	460	460	460	460
		290	290	290	290	290	290	290
		75	75	75	75	75	75	75
		354 439	354 439	354 439	354 439	354 439	460 580	354 439
		460	460	460	460	460	460	460
		345	345	345	345	345	345	345
		40	40	40	40	40	40	40
DRAW-OUT TYPE ⑩								
		360 445	360 445	360 445	360 445	360 445	466 586	360 445
		460	460	460	460	460	460	460
		290	290	290	290	290	290	290
		75	75	75	75	75	75	75
		354 439	354 439	354 439	354 439	354 439	460 580	354 439
		460	460	460	460	460	460	460
		345	345	345	345	345	345	345
		40	40	40	40	40	40	40

- ①: Values in open air at 40°C (45°C for marine applications).
- ②: Values of AR208S, AR212S, AR216S for draw-out type with horizontal terminals, Values of the other ACBs for draw-out type with vertical terminals.
- ③: For 2 pole ACBs use outside poles of 3 pole ACB.
- ④: 4poles ACBs without Neutral phases protection can not apply IT earthing system.
- ⑤: Cannot apply IT earthing system, i.e., insulated from earth.
- ⑥: For 500V AC.
- ⑦: AGR protection relays cannot be used for DC. Please contact TERASAKI
- ⑧: A special version of the breaker is available to use above 250V DC. Contact Terasaki for details.

- ⑨: Applicable to only 3 pole ACBs.
  - ⑩: For vertical terminals or horizontal terminals.
  - ⑪: These weights are based on normal specifications with the OCR and standard accessories.
  - ⑫: Comply with JIS C 8201-2-1 Ann.1 Ann.2
  - ⑬: Values for ACBs with INST. 100/220kA for ACBs with MCR.
  - ⑭: Can apply IT system with special specification. Contact TERASAKI for the detail.
  - ⑮: Available as standard.
  - \*: Contact TERASAKI for the ratings.
- Note: When the INST trip function is set to NON, the MCR function should be enabled, otherwise, the rated breaking capacity is reduced to the rated latching current.



# Ratings

High fault 2000	High fault 2000	Standard 2500	High fault 2500	Standard 3200	High fault 3200	Standard 4000	Standard 4000	High fault 4000	Standard 5000	Standard 6300	High fault 6300
AR320H	AR420H	AR325S	AR325H	AR332S	AR332H	AR440SB	AR440S	AR440H	AR650S	AR663S	AR663H
2000	2000	2500	2500	3200	3200	4000	4000	4000	5000	6300	6300
2000	※	2500	2500	3200	3200	3310	3700	3700	4700	5680	5680
2000	2000	2500	2500	3200	3200	4000	4000	4000	5000	6300	6300
2000	2000	2500	2500	3200	3200	4000	4000	4000	5000	6300	6300
3   4	3	3   4	3   4	3   4	3   4	3   4	3   4	3	3   4	3   4	3   4
2000	800	2500	2500	3200	3200	4000	4000	4000	5000	6300	5000
	2000										6300

$1000 \leq I_n \leq 2000$	$400 \leq I_n \leq 800$ $1000 \leq I_n \leq 2000$	$1250 \leq I_n \leq 2500$	$1250 \leq I_n \leq 2500$	$1600 \leq I_n \leq 3200$	$1600 \leq I_n \leq 3200$	$2000 \leq I_n \leq 4000$	$2000 \leq I_n \leq 4000$	$2000 \leq I_n \leq 4000$	$2500 \leq I_n \leq 5000$	$3150 \leq I_n \leq 6300$	$2500 \leq I_n \leq 5000$ $3150 \leq I_n \leq 6300$
---------------------------	--	---------------------------	---------------------------	---------------------------	---------------------------	---------------------------	---------------------------	---------------------------	---------------------------	---------------------------	--

1000	1000	1000	1000	1000	1000	1000	1000	1000	1000	1000	1000
690	690	690	690	690	690	690	690	690	690	690	690
85/187	75/165 ⑤	65/143 ⑤	85/187	65/143 ⑤	85/187	85/187	75/165 ⑤	75/165 ⑤	85/187 ⑭	85/187 ⑤	85/187 ⑤
100/220	120/264 ⑬	85/187 ⑥	100/220	85/187 ⑥	100/220	100/220	100/220	120/264 ⑬	120/264	120/264	135/297
50/115	65/149.5	50/115	50/115	50/115	50/115	50/115	65/149.5	65/149.5	65/149.5	65/149.5	65/149.5
80/184	75/172.5	65/149.5	80/184	65/149.5	80/184	80/184	75/172.5	75/172.5	80/184	80/184	80/184
100/230	120/276	85/195.5	100/230	85/195.5	100/230	100/230	100/230	120/276	100/230	100/230	100/230
40/40	40/40	40/40	40/40	40/40	40/40	40/40	40/40	40/40	40/40	40/40	40/40
85/201	75/179	65/153	85/201	65/153	85/201	—	75/179	75/179	85/201	85/201	85/201
100/233	120/287	85/201 ⑥	100/233	85/201 ⑥	100/233	—	100/245	120/287	120/287	120/287	138/322
85/201	75/179	65/153	85/201	65/153	85/201	85/198	75/179	75/179	85/201	85/201	85/201
100/233	120/287	85/201 ⑥	100/233	85/201 ⑥	100/233	100/233	100/245	120/287	120/287	120/287	138/322
⑮	⑮	⑮	⑮	⑮	⑮	⑮	⑮	⑮	⑮	⑮	⑮
12	12	12	12	12	12	12	12	12	12	12	12
100	100	85	100	85	100	100	100	100	120	120	135
75	85	65	75	65	75	75	85	85	85	85	85
85	100	85	85	85	85	85	100	100	120	120	120
0.03	0.03	0.03	0.03	0.03	0.03	0.03	0.03	0.03	0.05	0.05	0.05
10	10	10	10	10	10	10	10	10	10	10	10
0.08	0.08	0.08	0.08	0.08	0.08	0.08	0.08	0.08	0.1	0.1	0.1
25000	15000	20000	20000	20000	20000	15000	15000	15000	10000	10000	10000
12000	8000	10000	10000	10000	10000	8000	8000	8000	5000	5000	5000
10000	3000	7000	7000	7000	7000	3000	3000	3000	1000	1000	1000
7000	2500	5000	5000	5000	5000	2500	2500	2500	500	500	500
56   68	71	56   68	56   68	56   68	56   68	58   71	71   92	71	125   160	140   180	140   180
49   57	76	49   57	49   57	49   57	49   57	68   87	68   84	76	75   100	80   105	80   105
105   125	147	105   125	105   125	105   125	105   125	126   158	139   176	147	200   260	220   285	220   285
80   92	—	80   92	80   92	80   92	80   92	—   —	—   —	—	—   —	—   —	—   —
466   586	—	466   586	466   586	466   586	466   586	—   —	—   —	—	—   —	—   —	—   —
460	—	460	460	460	460	—	—	—	—	—	—
290	—	290	290	290	290	—	—	—	—	—	—
75	—	75	75	75	75	—	—	—	—	—	—
460   580	631	460   580	460   580	460   580	460   580	460   580	631   801	631	799   1034	799   1034	799   1034
460	460	460	460	460	460	460	460	460	460	460	460
345	375	345	345	345	345	345	375	375	380	380	380
40	53	40	40	40	40	140	53	53	60	60	60





# Specifications

TemPower 2 series ACBs have an extensive range of accessories available, enabling the ACBs to be “custom built” to suit every application.

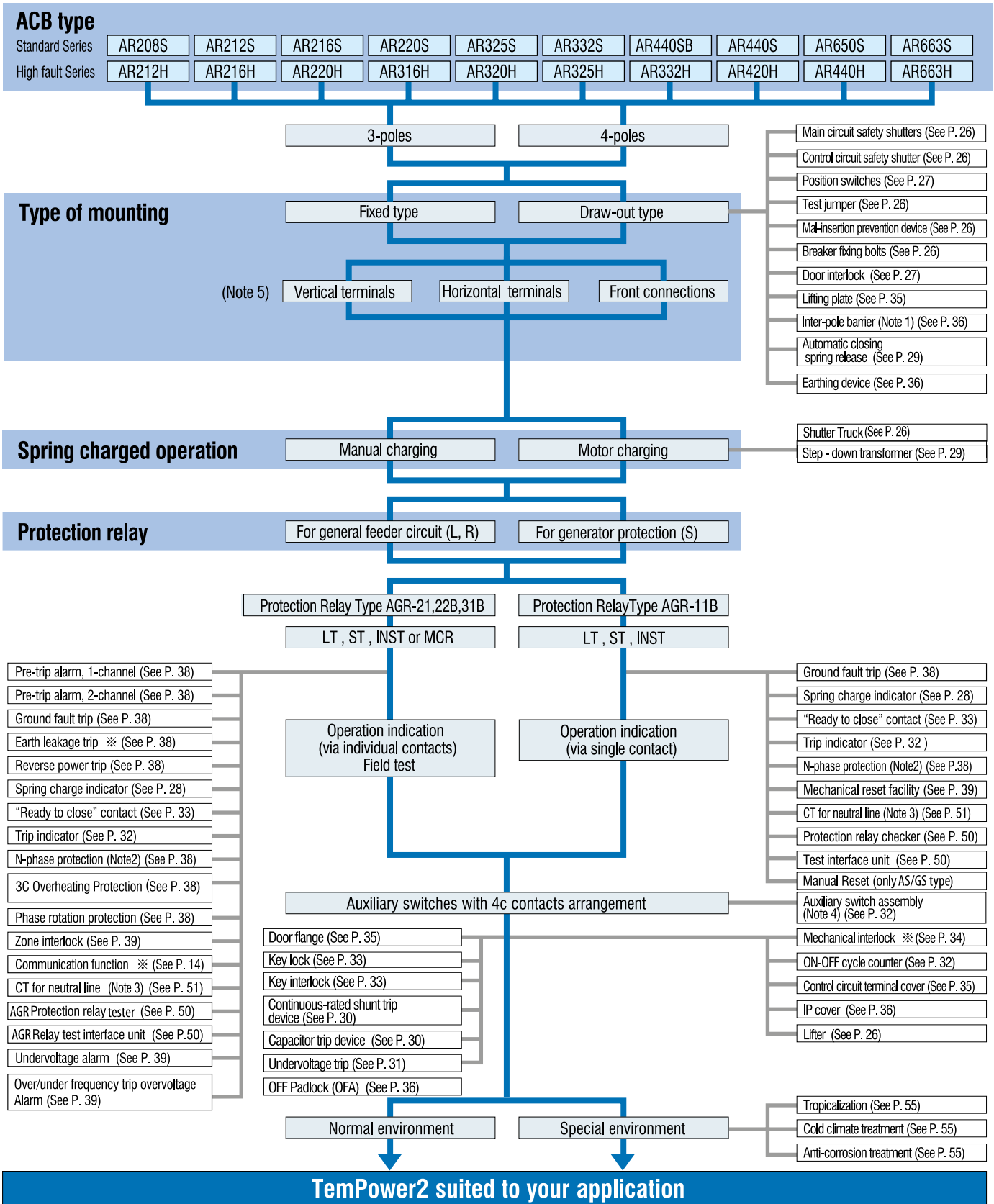

Note 1: Not applicable to ACBs equipped with front connections.

Note 2: Applicable to 4-pole ACBs.

Note 3: Required for ground fault protection for 3-poles ACB on 3-phase, 4-wire systems.

Note 4: Microload switch assembly with 3c arrangement available.

Note 5: Vertical terminal is standard and horizontal terminal is optional for High fault series. Front connection is not available for High fault series.

※: Contact Terasaki for details.



## Types of Mounting

### Draw-out type

This type of ACB consists of a breaker body and a draw-out cradle. The breaker body can be moved within or removed from the draw-out cradle that is fixed in the switchboard.

There are four breaker body positions: CONNECTED, TEST, ISOLATED and WITHDRAWN. The switchboard panel door can be kept closed in the CONNECTED, TEST and ISOLATED positions ("shut-in three positions").

**CONNECTED position**

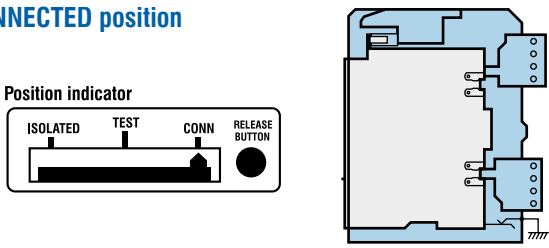

Both the main and control circuits are connected for normal service.

**TEST position**

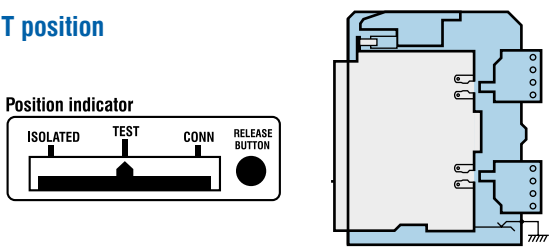

The main circuit is isolated and the control circuits are connected. This position permits operation tests without the need for opening the switchboard panel door.

**ISOLATED position**

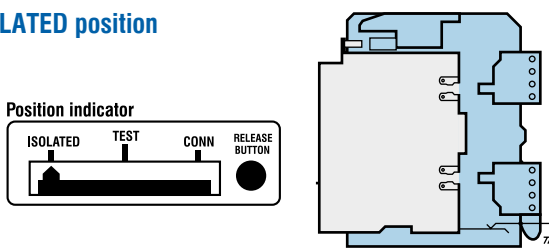

Both the main and control circuits are isolated. The switchboard panel door does not need to be opened.

**WITHDRAWN position**

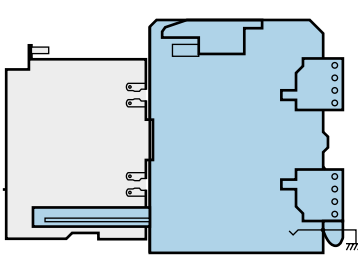

The breaker body is fully withdrawn from the draw-out cradle.

### Fixed type

This type of ACB has no draw-out cradle and is designed to be directly mounted in the switchboard.

### Terminal arrangements

#### Main Circuit terminals

Three (3) types of main circuit terminal arrangements are available: vertical terminals, horizontal terminals and front connections. Different types of terminal arrangements can be specified for the line and load sides.

Note: The max. rated current [In] may be reduced depending on the main circuit terminal arrangement. For more information see page 84.

Type	Vertical terminals	Horizontal terminals	Front Connection
AR208S, AR212S, AR216S	○	⊙	○
AR220S, AR325S, AR332S	⊙	○	○
AR212H, AR216H, AR220H, AR316H, AR320H, AR325H, AR332H	⊙	●	—
AR440SB, AR440S, AR650S, AR663S, AR420H, AR440H, AR663H	⊙	—	—

⊙ : Standard. This configuration used unless otherwise specified.  
○ : Optional standard. Specify when ordering.  
● : "yes" or "available". — : "no" or "not available".



Horizontal terminals



Vertical terminals



Front connections

#### Control circuit terminals

Control circuit terminals are front located to allow easy wiring/access.

The terminal blocks (for auxiliary switches, position switches and control circuits) are positioned on the top of the ACB front panel and can be accessed from the front for wiring.

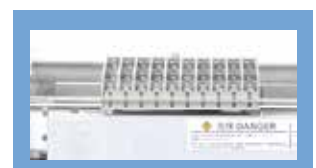

M4 screw terminals are standard.



# Choosing Accessories and a Protection Relay

## SECTION

## 3

▶	<b>ACB Accessories</b> .....	<b>28-38</b>
	Accessories for draw-out type .....	<b>28</b>
	Position Switches .....	<b>29</b>
	Spring Charged Operation .....	<b>30-31</b>
	Trip Devices .....	<b>32-33</b>
	Other Accessories .....	<b>34-38</b>
▶	<b>Protection Relays</b> .....	<b>39-53</b>
	Protection Relay Selection Table .....	<b>42-43</b>
	L-characteristic for general feeder circuits (Type AGR-11BL, 21BL, 31BL).....	<b>44-45</b>
	R-characteristic for general feeder circuits (Type AGR-21BR, 31BR) .....	<b>46-47</b>
	S-characteristic for general feeder circuits (Type AGR-21BS, 22Bs, 31BS) .....	<b>48-49</b>
	Protection Relay Accessories .....	<b>50-51</b>



## Accessories for Draw-out Type

### Main circuit safety shutters

The main circuit safety shutters automatically conceal the main circuit contacts on the draw-out cradle when the ACB is drawn out.

- The top and bottom shutters operate independently and can be separately padlocked in the closed position.
- Up to three padlocks (with  $\varnothing.6$  hasp) can be installed on each side using padlocking unit. (Padlock not supplied).
- In the closed position, the shutters be easily unlocked by hand. They can be unlocked and held open if required for the purpose of inspection or maintenance.



### Shutter opening truck

The shutter opening truck is used to open the main circuit safety shutters without reaching inside the chassis.



### Lifter

A special lifter is available to allow easy and safe transportation or installation of the ACB. A drop prevention mechanism is standard.

### ACB mounting position

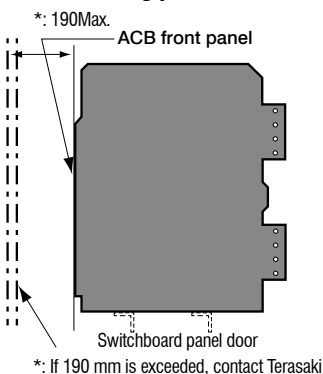

### Control circuit safety shutters

The control circuit safety shutter covers the control circuit contacts, ensuring safety.



### Test jumper

The test jumper is a plug-in type, and allows ON-OFF tests on all the **TemPower 2** series ACBs with the breaker body drawn out from the draw-out cradle. The standard jumper cable is 5 m long.



### Breaker fixing bolts

The breaker fixing bolts hold the breaker body securely to the draw-out cradle in position. Use them if the ACB is subject to strong vibration.



### Position padlock lever

Using the position padlock lever prevents the breaker body from inadvertently being drawn out. The position padlock lever in the pulled-out position locks the breaker body in the CONNECTED, TEST or ISOLATED position. Up to 3 padlocks (with  $\varnothing.6$  hasp) can be installed (supplied as standard).



### Mal-insertion prevention device

Interchangeability exists within the **TemPower 2** series of ACBs. Because of this feature, there is a possibility for an ACB of a different specification being placed into the draw-out cradle. Using the mal-insertion prevention device eliminates such a possibility.

This device is capable of distinguishing nine different breaker bodies.

Please specify the Code 1A, 1B, 1C, 2A, 2B, 2C, 3A, 3B, 3C for each ACB.

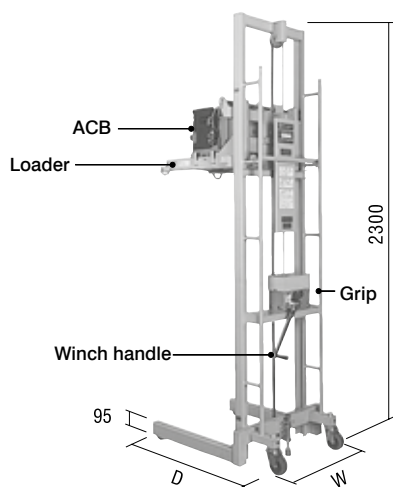

Type of Lifter	Weight (kg)	D (mm)	W (mm)	Applicable ACBs
AWR-1B	92	887	710	AR2, AR3, AR440SB
AWR-2B	110	912	1150	AR2, AR3, AR4, AR6

## Position Switches

The position switch operates to give an indication of the breaker position: CONNECTED, TEST, ISOLATED and INSERT. There are two contact arrangements: 2c and 4c.

Connections to the switches are made via screw type terminals.

The following table lists the available types of the switches:

Type	Number of contacts	Contact Arrangement			
		INSERT	ISOLATED	TEST	CONN
ALR-0110P	2c	0	1	1	0
ALR-0101P		0	1	0	1
ALR-0011P		0	0	1	1
ALR-0200P		0	2	0	0
ALR-0020P		0	0	2	0
ALR-0002P		0	0	0	2
ALR-1111P	4c	1	1	1	1
ALR-1210P		1	2	1	0
ALR-1201P		1	2	0	1
ALR-0211P		0	2	1	1
ALR-1120P		1	1	2	0
ALR-1021P		1	0	2	1
ALR-0121P		0	1	2	1
ALR-1102P		1	1	0	2
ALR-1012P		1	0	1	2
ALR-0112P		0	1	1	2
ALR-0220P		0	2	2	0
ALR-0202P		0	2	0	2
ALR-0022P		0	0	2	2
ALR-1030P		1	0	3	0
ALR-0130P		0	1	3	0
ALR-00031P		0	0	3	1
ALR-1003P		1	0	0	3
ALR-0103P		0	1	0	3
ALR-0013P	0	0	1	3	
ALR-0040P	0	0	4	0	
ALR-0004P	0	0	0	4	

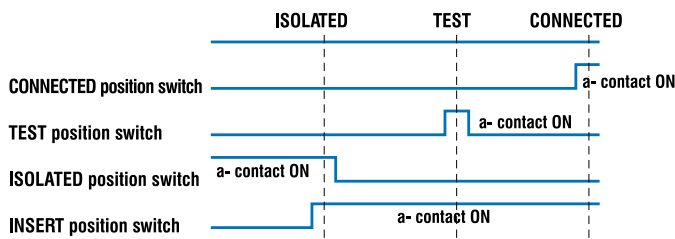

INSERT position means the breaker body is in any position between ISOLATED and CONNECTED.

Voltage	Resistive Load (A)	Inductive load (A) (COS φ = 0.6, L/R = 0.07)
AC 100 - 250V	11	6
DC 250V	0.3	0.3
DC 125V	0.6	0.6
DC 30V	6	5
DC 8V	10	6

The door interlock prevents the switchboard door from being opened unless the breaker body is in the ISOLATED position. When the draw-out handle is removed while the ACB is in the ISOLATED position, the interlock is released and the switchboard door can be opened.

The breaker body cannot be inserted unless the switch board door is closed. Contact Terasaki for details.

**Note 1:** When the door interlock is installed, the standard draw-out handle cannot be stored in the switchboard. A storage drawout handle is available as an option. The storage draw-out handle can be housed flushed with the front surface of the ACB. (The storage handle will incur an extra cost).

**Note 2:** Door interlock not compatible with fixing bolts unless suitable panel door is arranged.



## Spring Charged Operation

### Manual charging type

For this type of ACB, the closing springs are charged by means of the spring charging handle. ON/OFF operation of the ACB is performed by means of the ON /OFF buttons on the ACB.

■ **Charging the closing springs**

Pumping the spring charging handle by hand charges the closing springs.

■ **Closing the ACB**

Pressing the ON button on the ACB closes the ACB.

■ **Opening the ACB**

Pressing the OFF button on the ACB opens the ACB. The ACB cannot be closed as long as the OFF button is pressed.

### Motor charging type

For this type of ACB, the closing springs are charged by means of a motor. ON/OFF operation of the ACB can be performed remotely. A manual charging mechanism is also fitted to facilitate inspection or maintenance work.

■ **Charging the closing springs**

A motor is used to charge the closing springs. When the closing springs are released to close the ACB, they are automatically charged again by the motor for the next ON operation.

■ **Closing the ACB**

Turning on “remote” ON switch enables the ACB to be remotely closed.

- Anti pumping mechanism  
Even if the ON switch is kept on, ACB closing operation is performed only once. To close the ACB again, remove the ON signal to reset the anti-pumping mechanism and then reapply the ON signal.
- If ON and OFF signals are simultaneously given to the ACB, the ON signal is ignored.
- ON signal should be given to the ACB on an over 200ms after OFF signal.

■ **Opening the ACB**

For opening the ACB remotely specify the shunt trip device (see page 30) or the undervoltage trip (see page 31).

### Operation power supply

Rated voltage (V)	Applicable voltage range (V)		Operation power supply ratings		
	CHARGE/ ON operation	OFF operation (Note 1)	Motor inrush current (peak) (A)	Motor steady-state current (A)	Closing command current (peak) (A)
AC100	85-110		7	1.1	0.29
AC110	94-121		7	1.1	0.25
AC120	102-132		7	1.1	0.22
AC200	170-220		4	0.7	0.15
AC220	187-242		4	0.7	0.13
AC240	204-264		4	0.7	0.11
DC24	21-26		14	4	1.04
DC48	41-53		10	1.6	0.51
DC100	85-110		6	0.8	0.25
DC110	94-121		6	0.8	0.22
DC125	107-138		6	0.8	0.21
DC200	170-220		4	0.5	0.13
DC220	187-242		4	0.5	0.12

Note 1: For the ratings refer to the shunt trip device on page 30.

\* Split circuit for motor and closing coil available on request.

## Accessories for Spring Charged Operation

### Automatic closing spring release

This device allows the charged closing springs to be automatically released when the ACB is drawn out.

ANSI or NEMA-compliant ACBs require this option.

### Spring charge indicator

This switch can be used to indicate that the closing springs have been fully charged.

#### ■ Normal contacts for general service

Rated control voltage		Switch contact ratings	
		Resistive load	Inductive load
AC	250	3	3
	250	0.1	0.1
DC	125	0.5	0.5
	30	3	2

Minimum applicable load is DC24V 10mA.

#### ■ Gold contacts for microload

Rated control voltage		Switch contact ratings	
		Resistive load	Inductive load
AC	250	0.1	0.1
DC	30	0.1	0.1

Minimum applicable load is DC24V 1mA.

### Step-down transformer (external)

The maximum rated control voltage applicable to the operation power supply is AC240V. For higher voltages, a step-down transformer is needed.

The following step-down transformers are available as options:

Rated control voltage	Transformer		
	Type	Capacity	Voltage ratio
AC410 - 470VT	SE-30M	300VA	450/220V
AC350 - 395VT	SE-30M	300VA	380/220V



## Trip Devices

### Continuously-rated shunt trip device

The continuous rated shunt trip device allows the ACB to be opened when an external protection relay against overcurrent or reverse power is activated.

Because of its continuous rating, the device can also be used to provide an electrical interlock to the ACB.

Continuously rated shunt trip and undervoltage trip can not be fitted to the same ACB. However by fitting a special continuously rated shunt trip to the side plate of an ACB chassis will allow an undervoltage trip to be used in conjunction with a continuously rated shunt trip. A mechanical interlock cannot be fitted with this combination.

Instantaneously rated shunt trip also available with special specification. This shunt trip can be fitted with undervoltage trip to the same ACB.

Special double opening and closing coils are available.

### Capacitor trip device

In conjunction with the continuously-rated shunt trip device, the capacitor trip device can be used to trip the ACB within a limited period of 30 sec if a large voltage drop occurs due to an ac power failure or short-circuit.

When the continuously-rated shunt trip is used with a capacitor trip device, “a” contact of auxiliary switch of ACB should be inserted in series, otherwise internal damage may occur.

Type	Rated voltage (V)	Operational voltage (V)	Max excitation current (A)	Opening time (max.) (ms)
AVR-1C	AC100	AC70-110	0.29	50 ※
	AC110	AC77-121	0.25	
	AC120	AC84-132	0.22	
	AC200	AC140-220	0.15	
	AC220	AC154-242	0.13	
	AC240	AC168-264	0.11	
	DC24	DC16.8-26.4	1.04	
	DC30	DC21-33	0.85	
	DC48	DC33.6-52.8	0.51	
	DC100	DC70-110	0.25	
	DC110	DC77-121	0.22	
	DC125	DC87.5-137.5	0.21	
	DC200	DC140-220	0.13	
	DC220	DC154-242	0.12	

Note: It is not possible to test the capacitor trip device when the test jumper is used.

Type	AQR-1
Rated Voltage A	AC100-120V
Operational Voltage	Rated Voltage x 70 to 110%
Rated frequency	50/60Hz
Rated Voltage of Shunt Trip Used	DC48V
Power Consumption	100VA

#### • Control Circuit

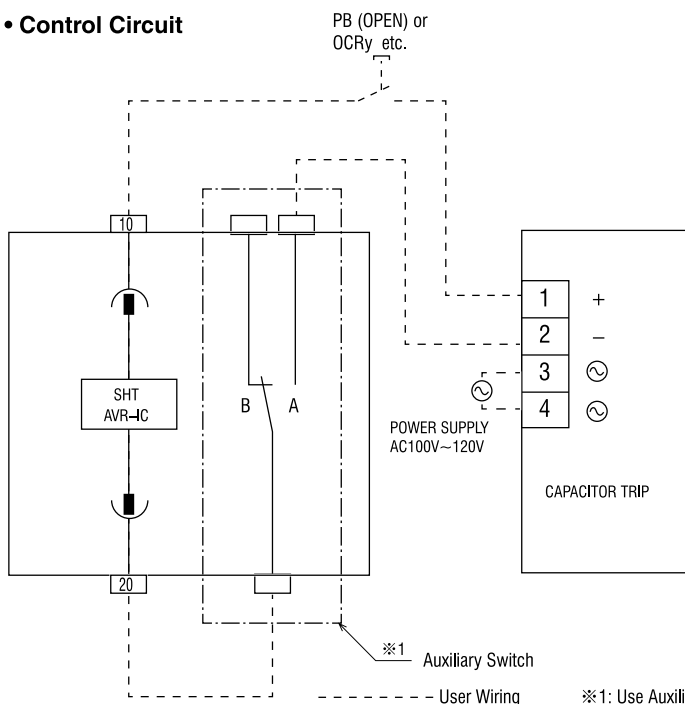

#### • Outline Dimensions

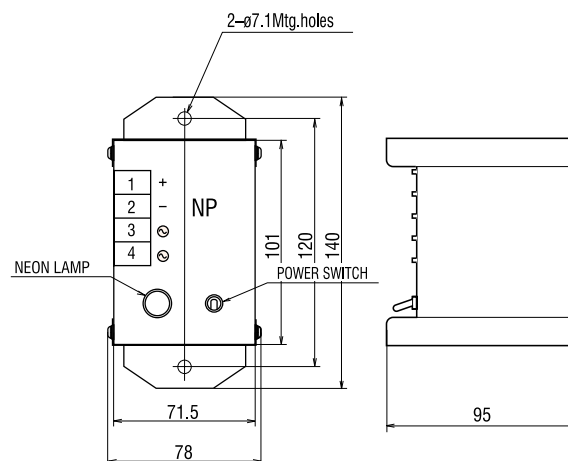

### Undervoltage trip device (UVT)

The undervoltage trip device (UVT) trips the ACB when the control voltage drops below the opening voltage. When the control voltage is restored to the pick-up voltage, the ACB can be closed. The pick-up voltage is fixed to 85% of the rated voltage.

The UVT consists of a tripping mechanism and an undervoltage trip control device. The trip control device is available in two types: AUR-ICS and AUR-ICD.

Type AUR-ICS provides an instantaneous trip (below 200ms) to the ACB when the control voltage drops below the opening voltage.

Type AUR-ICD provides a delayed trip to the ACB when the control voltage remains below the opening voltage for at least 500ms. ※

Adding a pushbutton switch (with normally opened contacts) between terminals [24] and [30] allows the ACB to be tripped remotely.

※ Time-delay trip over 1 sec. or 3 sec. is available as special specification

### Undervoltage trip control circuit (for AC)

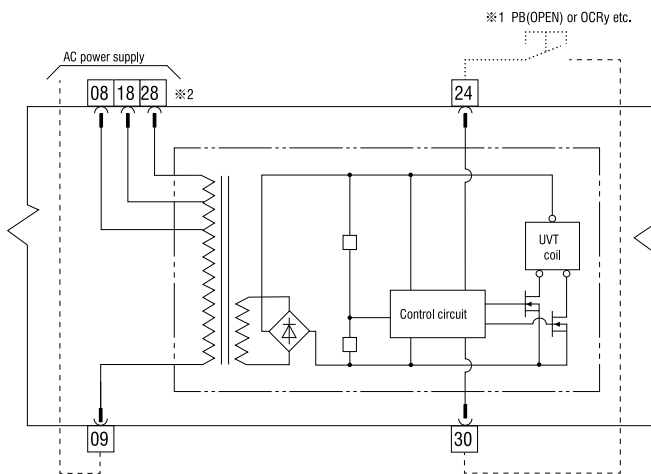

- ※ 1 Tripping signal is 48 VDC/5 mA.  
Apply tripping signal for at least 80 ms.
- ※ 2 For DC type use 09 as the (-) terminal and 08 as the (+) terminal.

It takes max. 1.5 sec. for UVT coil to be absorbed after the rated voltage is applied to the undervoltage trip device. Therefore, for the closing command, the closing signal should be applied on and over 1.5 sec. after the rated voltage is applied.

Type of UVT Control Device	Rated Voltage 50/60Hz (V)	Opening Voltage (V)	Pick-up Voltage (V)	Coil Excitation Current (A)	Power Consumption (VA)		
					Normal	Reset	
AUR-1CS AUR-1CD	AC	100	35-70	85 or less	0.1	8	10
		110	38.5-77	93.5 or less			
		120	42 - 84	102 or less			
		200	70 -140	170 or less			
		220	77 - 154	187 or less			
		240	84 - 168	204 or less			
		380	133 - 266	323 or less			
		400 ※ 3	140 - 280	340 or less			
		415	145 - 290	352 or less			
		440	154 - 308	374 or less			
		450 ※ 3	157.5 - 315	382.5 or less			
	480 ※ 3	168 - 336	408 or less				
	DC	24 ※ 3	8.4 - 16.8	20.4 or less	0.1	8	10
		48 ※ 3	16.8 - 33.6	40.8 or less			
		100 ※ 3 ※ 4	35 - 70	85 or less			
220V ※ 3		※ 5	※ 5				

※ 3: Special specification  
 ※ 4: Not possible to fit with Instantaneously rated shunt trip.  
 ※ 5: Contact Terasaki



## ON-OFF cycle counter

The ON-OFF cycle counter is a mechanical 5-digit readout that shows the number of ON-OFF cycles of the ACB.

Counter readings serve as a guide for maintenance or inspection.



## Auxiliary switches

The auxiliary switches operate during the ACB ON/OFF operation.

Connections to the switches are made via screw terminals. The auxiliary switches for draw-out type ACBs operate in the CONNECTED and TEST positions.

The auxiliary switches for ACBs conforming to classification society's rules operate in the CONNECTED position only. The auxiliary switches have change-over contacts and are available for general service and for microload.

Type	Normal contacts for general service	Gold contacts for microload ※※
※ AXR-004	4c	---
AXR-007	7c	---
AXR-304	4c	3c
AXR-010	10c	---
AXR-307	7c	3c

※ The standard contact arrangement of the auxiliary switches is 4c. (Form c: Change-over, single gap, three terminals)

※※ Suited to electronic circuits

Note: 4c is the maximum arrangement when any one of the ground fault protection on the line side, zone interlock, or communication function is incorporated or in the case of type AGR-31B Protection relay with the ground fault trip function incorporated.

## Auxiliary switch ratings

Category	For general service			For microload ※※※			Min. applicable load
	Resistive load (A)	Inductive load (A)	AC: $\cos \phi \geq 0.3$ DC: $L/R \leq 0.01$	Resistive load (A)	Inductive load (A)	AC: $\cos \phi \geq 0.6$ DC: $L/R \leq 0.007$	
AC100-250V	5		5	0.1		0.1	DC5V 1mA
AC251-500V	5		5	---		---	
DC30V	1		1	0.1		0.1	
DC125-250V	1		1	--		---	

Note 1: The chattering of b-contacts due to ON-OFF operation of the ACB lasts for less than 20 ms.

Note 2: Do not supply different voltages to contacts of a switch.

## Momentary Trip Indicator/Closing Inhibited Indicator

This indicator contact has two applications:

- It can indicate a trip by overcurrent release, shunt trip, undervoltage trip or manual pushbutton trip. Operation is according to the table. Note that indication is momentary (45ms) under some conditions. Use a relay holding circuit if continuous indication is required under these conditions.
- The contact indicates that closing is inhibited by the status of closing springs, overcurrent release, shunt trip, undervoltage trip, pushbuttons or another interlock as described in the table.

Cause of trip	Springs charged	Springs discharged
Protection relay	Switch is ON for 40ms, then reset to OFF	Switch remains ON until closing springs are charged
Shunt Trip	Switch is ON for 40ms, then reset to OFF	Switch remains ON until closing springs are charged
Remote opening function of UVT	Switch is ON for 40ms, then reset to OFF	Switch remains ON until closing springs are charged
Actual undervoltage condition	Switch is ON until undervoltage condition is restored to normal	Switch remains ON until springs are charged after undervoltage condition is restored to normal
Manual opening by pushbutton	Switch remains ON until pushbutton is released	Switch remains ON until springs are charged after pushbutton is released

## Normal contacts for general service

Voltage (V)	Switch contact ratings	
	Resistive load	Inductive load
AC 250	3	3
DC 250	0.1	0.1
DC 125	0.5	0.5
DC 30	3	2

Minimum applicable load is DC24V 10mA.

## Gold contacts for microload

Voltage (V)	Switch contact ratings	
	Resistive load	Inductive load
AC 250	0.1	0.1
DC 30	0.1	0.1

Minimum applicable load is DC24V 1mA.

### “Ready to close” contact (special specification)

The “ready to close” contact indicates that the ACB is in a ready to close status.

This contact operates when the following are valid:

- ON-OFF indicator shows “OFF”. (The ACB is in OFF position)
- Spring charge indicator shows “charged”
- Undervoltage trip is energised
- Shunt trip is not energised
- ACB is in the connected or test position
- Key lock and Key interlock are off
- Mechanical interlock is off

### Key Lock

The key lock is available in two types: the lock-in ON type that locks the ACB in the closed position, and the lock-in OFF type that locks the ACB in the open position.

When the ACB is fitted with a key lock, the operator cannot operate the ACB unless using a matched key.



### Ratings and Specifications

#### ■ Normal contacts for general service

Voltage (V)	Switch contact ratings	
	Resistive load	Inductive load
AC 250	3	3
DC 250	0.1	0.1
DC 125	0.5	0.5
DC 30	3	2

Minimum applicable load is DC24V 10mA.

#### ■ Gold contacts for microload

Voltage (V)	Switch contact ratings	
	Resistive load	Inductive load
AC 250	0.1	0.1
DC 30	0.1	0.1

Minimum applicable load is DC24V 1mA.

### Key interlock

The key interlock is a system of interlocking between ACBs, each fitted with a key lock of lock-in OFF type.

- A key must be inserted to release the lock before the ACB can be closed
- The ACB must be opened and locked in the OFF position before the key can be removed.

By utilising the lock-in OFF type key lock feature, and then a limited number of keys by default provides an effective and reliable interlock system. Using the same keys also allows interlocking between and ACB and other devices (such as switchboard door).

ACBs can be supplied with a cylinder lock or type FS-2 Castell lock (with an angular movement 90° clockwise to trap key).

A double Castell interlocking facility suitable for applications such as UPS systems is available as a special specification, contact Terasaki Electric Europe, UK. Facility or full option including locks are available, please specify. For other lock types contact Terasaki. (Ronis available).

### Example: Interlock for prevention of parallel feeding from two sources

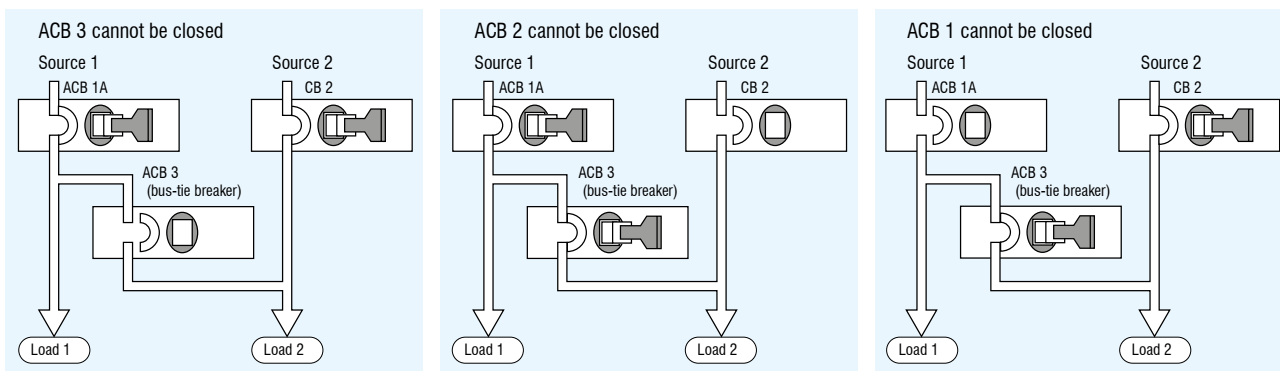



## Mechanical interlocks (contact TERASAKI for details)

Cable type interlocks for 2 or 3 ACBs in either horizontal or vertical arrangements are available. Rod type mechanical interlocks are available for vertical interlocking of ACBs.

Interlocking is possible between any frame size within the **TemPower 2** range.

In conjunction with an electrical interlock, it will enhance safety and reliability of power distribution systems.

### Horizontal type

Left ACB \ Right ACB		Right ACB			
		AR208S ~ AR220S AR212H ~ AR220H	AR325S ~ AR332S AR316H ~ AR332H AR440SB	AR440S AR420H ~ AR440H (3P only)	AR650S ~ AR663S AR663H
		3P, 4P	3P, 4P	3P, 4P	3P, 4P
AR208S ~ AR220S AR212H ~ AR220H	3P	600, 700, 800	600, 700, 800	600, 700, 800	800, 1000, 1100
	4P	600, 700, 800, 900	700, 800, 900	600, 700, 800, 900	900, 1000, 1100
AR325S ~ AR332S AR316H ~ AR332H AR440SB	3P	600, 700, 800, 900	700, 800, 900	600, 700, 800, 900	900, 1000, 1100
	4P	700, 800, 900, 1000	800, 900, 1000	700, 800, 900, 1000	1000, 1100, 1200
AR440S AR420H ~ AR440H (3P only)	3P	800, 900, 1000, 1100	800, 900, 1000, 1100	800, 900, 1000, 1100	1100, 1200, 1300
	4P	1000, 1100, 1200, 1300	1000, 1100, 1200, 1300	1000, 1100, 1200, 1300	1300, 1400
AR650S ~ AR663S AR663H	3P	700, 800, 900, 1000	800, 900, 1000	700, 800, 900, 1000	1000, 1100, 1200
	4P	1000, 1100, 1200	1000, 1100, 1200	1000, 1100, 1200	1200, 1300, 1400

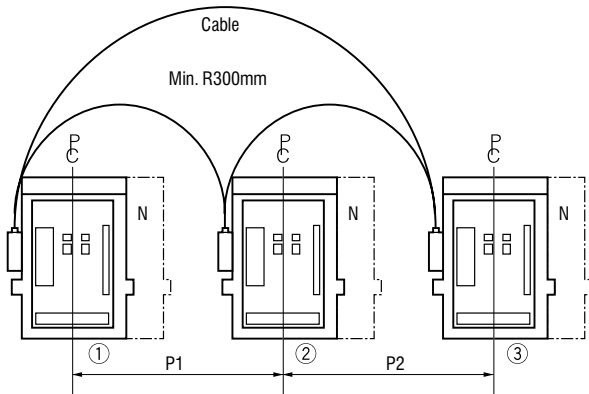

To order, select the required pitch for P1 and P2 from the above table and specify the type and number of poles for each ACB.

#### Example:

P1: 700 mm

P2: 800 mm

ACB ①: Type **AR212H** 3 poles

ACB ②: Type **AR332H** 3 poles

ACB ③: Type **AR216H** 3 poles

### Vertical type

Minimum pitch (550mm) is possible.

Specify the required pitch when ordering.

Maximum is 1200mm.

Contact TERASAKI for details of vertical type with 3 ACBs.

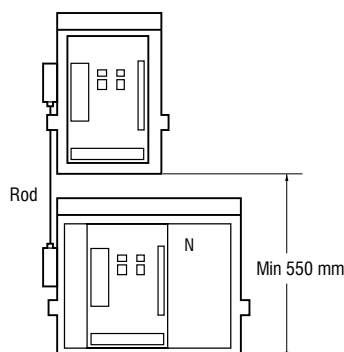

### Types and Operations

Type	Operation			Remark
	Br1	Br2	Br3	
Type C 1	ON	OFF	/	One of two breakers can be turned on.
	OFF	ON	/	
	OFF	OFF	/	
Type B 2	ON	ON	OFF	One or two of three breakers can be turned on.
	ON	OFF	ON	
	OFF	ON	ON	
	ON	OFF	OFF	
	OFF	ON	OFF	
Type D 3	ON	OFF	OFF	One of three breakers can be turned on.
	OFF	ON	OFF	
	OFF	OFF	ON	
Type A 4	ON	OFF	ON	Br2 is interlocked with both Br1 and Br3.
	ON	OFF	OFF	
	OFF	ON	OFF	
	OFF	OFF	ON	
	OFF	OFF	OFF	

- Interlock is enabled in the CONNECTED position. When the breaker body is in the TEST, ISOLATED or DRAW-OUT position, interlock is disabled.
- If all of two or three breakers receive a closing (on) signal, they all will turn off. This case however involves a momentary continuity between the main circuit and the auxiliary switch a-contact in all the breakers.
- The body of a draw-out type breakers, as long as it is off (open), can be drawn out or inserted, irrespective of the state of other breakers. (Do not draw out or insert a breaker body during cable installation, adjustment or operation check).



## Lifting Plate

Lifting plates are detachable tools that can be used to lift a breaker body out of a draw-out cradle.



## Control circuit terminal cover

A control circuit terminal cover protects the terminal blocks for auxiliary switches, position switches and control circuits from being accidentally touched, thus enhancing safety.



## ON-OFF button cover

An ON-OFF button cover prevents inadvertent or unauthorised operation of the ON or OFF button. It can be locked with up to three padlocks with  $\varnothing 6$  hasp (supplied as standard). Padlocks are not supplied.



## Door Flange

A door flange can be used as a decoration panel that covers the cutout on the switchboard panel and provides IP20 protection. For IP31 protection please specify the door flange with a gasket.

Note: Door flange cannot be fitted with IP cover.

STANDARD: IP20  
WITH RUBBER SHIELD: IP31  
NOT REQUIRED IF IP55 IS USED

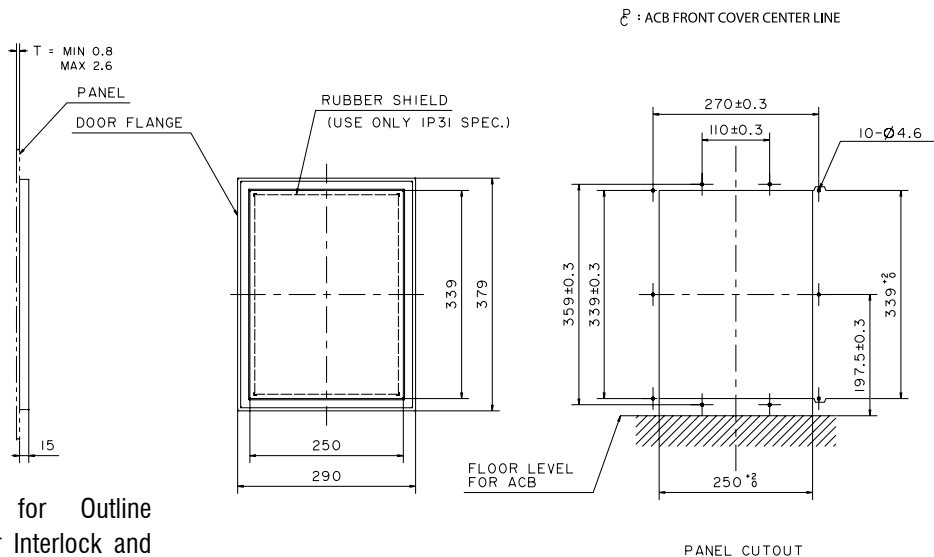

Contact Terasaki for Outline Dimensions of Door Interlock and Door Flange combination.

※ Mount IP20 door flange through 6 mounting holes and IP31 door flange through 10 mounting holes.

### OFF padlock (OFA)

Permits the ACB to be padlocked in the OFF position. Max, three padlocks with  $\varnothing 6$  hasp can be fitted. Padlocking is possible only when ON-OFF indicator shows OFF. When the ACB is padlocked in the OFF position both manual and electrical closing become inoperative, but the charging of the closing spring may manual or motor is still possible.

Note 1: OFF padlock facility cannot be fitted with key lock or key interlock.

### Inter-pole barrier

An inter-pole barrier prevents a possible short circuit due to foreign objects entering between the poles of the main circuit terminals or between the line and load ends, thus enhancing operation reliability of the ACB.

This barrier can be applied to the draw-out type ACB with vertical terminals or horizontal terminals.



### Earthing device

There is growing demand in L.V. distribution for greater protection against electric shock particularly during periods when maintenance work is being carried out on the main busbars or cables. A safe and economical way to meet this requirement is to apply system earthing via the normal service breaker. Earthing devices on **TemPower 2** ACBs comprises: Permanent parts which are factory fitted by Terasaki and are mounted on the ACB chassis and body to enable the ACB to receive the portable parts. Portable parts are supplied in loose kit form and are fitted on to the ACB body by the customer's engineer. This converts the ACB from a normal service device to an earthing device.

When the ACB is converted to the earthing device mode, the over-current release and the other electrical tripping devices are automatically disabled to prevent the remote opening of the ACB.

It is recommended that the ON-OFF operating buttons be padlocked to prevent manual opening of the ACB when used in the earthing mode.

Note: UVT function cannot be applied to the earthing device. Portable earthing device is not available for AR6, (earthing switch).

For further information contact Terasaki for details.

### IP cover

An IP cover provides an IP55 grade of protection as defined in IEC 60529. Even if the breaker body is on the ISOLATED position, IP cover can still be fitted on the ACB.

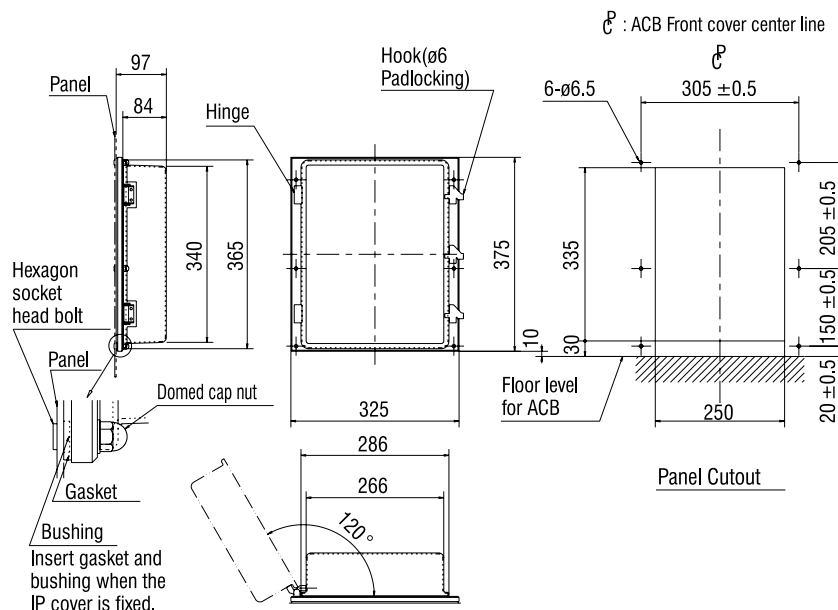

## Protection Relays

The AGR series of protection relays featuring high reliability and multiple protection capabilities is available for **TemPower 2**. Controlled by an internal 16-bit microprocessor, the protection relay provides reliable protection against overcurrent.

The protection relay range is divided into three groups: L-characteristic, R-characteristic (both for general feeder) and S-characteristic (for generator protection). Each group consists of:

**Type AGR-11B: Standard Protection relay with adjustment dial**

**Type AGR-21B: Standard Protection relay with L.C.D. (Backlit L.C.D. optional)**

**Type AGR-31B: Enhanced Protection relay with backlit L.C.D.**

Optional protection functions of the Protection relay include those against ground fault, earth leakage, undervoltage and reverse power. Pre-trip alarm function can also be installed.

An AGR-11B overcurrent mechanical reset facility is available for special application. For more information contact Terasaki.

### Protective functions

#### ① Adjustable long time-delay function LT

RMS sensing is used to accurately read through distorted wave forms.

In addition to the standard L and S-characteristics, the R-characteristic is available in five types for long time-delay trip. The R-characteristic can be used to give selectivity with e.g. fuses (see page 15).

#### ■ HOT start mode (applicable to L-characteristic of AGR-21B, 31B)

HOT or COLD start mode is user-selectable.

In HOT start mode, the Protection relay operates faster than in COLD start mode in response to an overload. The HOT start mode gives protection, taking account of the behaviour of loads under heat stress.

Note: In the standard shipment mode, COLD start mode is selected.

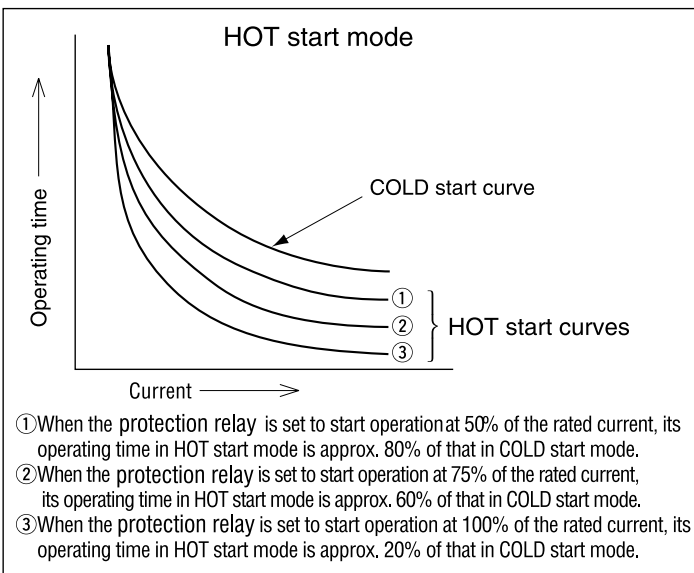

#### ② Adjustable short time-delay trip function ST

The ST delay trip function has a “definite time delay characteristic” and a “ramp characteristic”. These characteristics are selectable.

The ramp characteristic provides close selectivity with downstream circuit breakers or fuses.

The group AGR-L and AGR-R Protection relays come in operation with the definite time characteristic when the load current reaches 1000% or more of the rated current [ $I_n$ ] (500% or more of the rated current [ $I_n$ ] for AGR-S).

The ST trip function is factory set to the definite time characteristic.

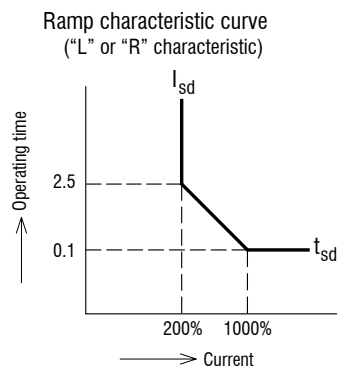

#### ③ Adjustable instantaneous trip function INST/MCR

The INST trip function trips the ACB when the short circuit current exceeds the pickup current setting, irrespective of the state of the ACB.

The making current release (MCR) trips the ACB when the short circuit current exceeds the pickup current setting during closing operation. After the ACB is closed, the MCR is locked and kept inoperative.

The INST and MCR are selectable for AGR-21B, 22B and 31B. (AGR-11B is INST only, MCR is not selectable).

Note: The MCR needs the control power. If the control power is lost, the MCR provides the INST trip function only.



### ④ Adjustable pre-trip alarm function PTA

The pre-trip alarm function provides an alarm signal via the alarm contact (1a-contact) when the load current exceeding a predetermined value lasts for a predetermined time. A 2-channel pre-trip alarm function is available for S-characteristic. This function can be used to adjust feeding to loads according to their priority.

The pre-trip alarm is automatically reset when the load current drops to the predetermined value. Note that this function needs the control power.

### ⑤ Ground fault trip function GF

The peak value sensing is used (the residual current of each phase is detected).

The GF pickup current can be set between 10% and 100% of the CT rated primary current [ $I_{CT}$ ]. Not available if CT primary current [ $I_{CT}$ ] is 400A or less.

<Ramp characteristic is added>

The ramp and definite time characteristics are selectable. The GF trip function comes into operation with the definite time characteristic when the load current reaches 100% or more of the CT rated primary current [ $I_{CT}$ ].

The GF trip function is factory set to the definite time characteristic.

When using a 3-pole ACB in a 3-phase, 4-wire system, be sure to use an optional CT for neutral line (see page 51).

**Note 1:** The GF trip function usually comes with operation indications. If you need nothing but ground fault indication without a ground fault tripping operation, specify at the time of ordering.

**Note 2:** Restricted and unrestricted ground fault protection **REF** is available as option. This enables protection against ground fault on the line side of the ACB.

### ⑥ N-phase protection function NP

This NP function is available on 4-pole ACBs and prevents the neutral conductor from suffering damage or burnout due to overcurrent.

The NP trip pickup current can be set between 40% and 100% of the Protection relay rated primary current for L and R-characteristics. For AGR-11B, it is factory set to a value specified at the time of ordering.

**Note 1:** The NP trip function comes usually with operation indications. The NP time-delay setting is shared by the LT trip function.

**Note 2:** The HOT start mode is available for AGR-21B and AGR-31B. The operating time for the NP trip function is linked to that for the LT trip function.

### ⑦ Earth leakage trip function ELT

(For AGR-31B only)

In conjunction with Zero phase Current Transformer (ZCT), the ELT function provides protection against earth leakage. The ELT pick up current can be set at 0.2, 0.3 and 0.5A (Medium sensitivity) or 1, 2, 3, 5 and 10A (Low sensitivity). This function needs the control power.

**Note 1:** Contact Terasaki for outline dimension of ACBs fitted with ZCT.

**Note 2:** For details on specifications of the external ZCT, contact Terasaki.

**Note 3:** The ELT function usually comes with operation indications. If you need nothing but earth leakage indications without earth leakage tripping operation, specify at the time of ordering.

**Note 4:** Contact Terasaki for applicable models.

### ⑧ Reverse power trip function RPT

(For AGR-22B and AGR-31B only) (ANSI-32R)

The RPT function protects 3-phase generators running in parallel against reverse power. The RPT pickup current can be set in seven levels: 4% thru 10% of the generator rated power. If the rated main circuit voltage exceeds 250 VAC, a step-down power transformer is needed. When ordering the ACB, state the step-down ratio of the transformer you will use.

### ⑨ Contact temperature monitoring function OH

(For AGR-22B and AGR-31B only)

The HEAT function prevents the ACB from suffering damage due to overheat. It monitors the temperature of the ACB main contacts and gives an alarm on the LCD and an output signal via the alarm contact (1a-contact) when the temperature exceeds 155°C.

The alarm can be manually reset when the temperature drops to a normal temperature.

If you want to set the threshold temperature to a lower value, contact Terasaki.

This function needs control power.

Note 1: "Alarm" or "Trip" can be selected.

### ⑩ Negative Sequence Current Protection Function NS

(For AGR-21B and AGR-31B only) (ANSI-46)

This function detects the negative-phase current occurring due to reverse phase or phase loss and prevents burnout of a motor or damage to equipment. The protection setpoint ranges from 20% to 100% of the main circuit rated current [ $I_n$ ].



## 11 Undervoltage alarm function UVA

(For AGR-22B and AGR-31B only) (ANSI-27A)

This function monitors the main circuit voltage and gives an alarm on the LCD and an output signal via an alarm contact when the voltage drops below the setting voltage.

The alarm is activated when the main circuit voltage drops below the setting voltage (selectable from 40%, 60% or 80% of the rated main circuit voltage [ $V_n$ ]).

If the rated main circuit voltage exceeds 250 VAC, a step-down power transformer is needed. When ordering the ACB, state the step-down ratio of the transformer you will use. ※

**Note 1:** The undervoltage alarm function is disabled once the main circuit voltage has risen to the recovery setting voltage or higher.

**Note 2:** If the undervoltage alarm function is used in conjunction with the undervoltage trip device (see page 31), an alarm may occur after the ACB trips open depending on the alarm setting voltage.

## 13 Zone interlock Z

(For AGR-22B and AGR-31B only)

The zone-selective interlock capability permits tripping of the ACB upstream of and nearest to a fault point in the shortest operating time, irrespective of the short time delay trip time setting, and minimises thermal and mechanical damage to the power distribution line.

### NON setting and fail-safe feature

#### 1 NON setting

Setting a trip pickup current function to NON allows you to render the corresponding protection function inoperative. Functions having the NON option include LT, ST, INST/MCR and GF.

Appropriate NON setting will be a useful means for optimum selectivity.

#### 2 Fail-safe feature

The Protection relay has a fail-safe mechanism in case protection functions are improperly set to NON.

**For AGR-11B:**

- If the ST and INST trip pickup current functions are both set to NON, the fail-safe mechanism will activate the INST trip function to trip the ACB when a fault current equal to or more than 16 times the rated current [ $I_n$ ] flows through the ACB.

**For AGR-21B, 22B, 31B:**

- If the ST trip pickup current function is set to NON, INST trip pickup current function cannot be set to NON and MCR cannot be selected.
- If the INST trip pickup current function is set to NON or if MCR is selected, ST trip pickup current function cannot be set to NON.

For AR663H, even if MCR is selected, the fail-safe mechanism will activate the INST trip function to trip the ACB when a fault current equal to or more than 16 times the rated current [ $I_n$ ] flows through the ACB.

### Field test facility

Type AGR-21B/22B/31B Protection relays are equipped with a field test function to verify the long time delay, short time delay, instantaneous and ground fault trip features without the need for tripping of the ACB.

To check type AGR-11B, use the type ANU-1 Protection relay checker (optional).

## 12 Overvoltage alarm and Over/under frequency protection V

(For AGR-31B only) (ANSI-810,81U,59A)

Over voltage alarm function monitors the main circuit voltage and gives an alarm on the LCD and an output contact when the voltage rises above the setting voltage.

The alarm is activated when the main circuit voltage rises above the setting voltage (selectable from 105% to 150% of the nominal circuit voltage).

If the rated main circuit voltage exceeds 250Vac a step-down transformer is needed. When ordering the ACB state the step-down ratio of the transformer required.

Over/under frequency protects whatever deviations from the nominal system frequency needs to be detected. The function monitors the main circuit frequency and gives an alarm on the LCD, output contact and trip option when the frequency deviates from the setting frequency.

Under frequency detection can be set between 80% to 105% of nominal frequency. Over frequency detection can be set between 95% to 140% of nominal frequency.

## 14 Mechanical reset facility

(For AGR-11BL - AS/GS only)

When the circuit breaker is tripped by the protection relay a reset button engages on the AGR. To release the ACB after a trip event the reset button will require activation (pressed).

※: Special version without step-down transformer

This version is specially applicable in the main-circuit voltage range from 250 to 690 VAC using the built-in register circuit board without requiring a step-down transformer. To request the version without a step-down transformer, specify your main circuit voltage.



## Operation Indication Function

### 1 Indication via single contact (AGR-11B)

When the LT, ST, INST or GF trip function is activated, an output is generated via 1a-contact.

The 1a-contact will turn off after 40ms or more. A self-hold circuit is needed.

### 2 Indication via individual contacts (AGR-21B, 22B, 31B)

When the LT trip, ST trip, INST/MCR trip, GF trip, ELT, RPT, NS, REF, UVT, pre-trip alarm, or contact temperature monitoring function is activated, LCD will indicate their operation individually and output is generated via the corresponding contact. The Protection relay also has a self-diagnostic feature that monitors the internal tripping circuits. If detecting any fault in the circuits, this feature turns on the system alarm indicator. The control power is needed.

#### Operation indications

○: Self-hold (Note 1)    ×: Auto-reset    △: status indication    —: Not applicable

Protective characteristic Function	L/R-characteristic		S-characteristic	
	LCD	Contact	LCD	Contact
LT · NP	○	○	○	× (Note 2)
ST	○	○ (Note 5)	○	× (Note 2 and 5)
INST/MCR	○	○ (Note 5)	○	× (Note 2 and 5)
GF (Ground fault) or ELT (Earth leakage)	○	○	—	—
OH (Contact temperature monitoring)	○	○	○	○
(Note 3) NS (Reverse phase)	○	○	—	—
REF (Line side GF)	○	○	—	—
Trip indication ※1	△	△	△	△
RPT (Reverse power trip)	—	—	○	× (Note 2)
PTA (Pretrip alarm)	×	×	×	×
PTA2 (Pretrip alarm)	×	×	×	×
(Note 4) UV (Undervoltage alarm)	○	△	○	△
Spring charge indication	△	△	△	△
System alarm	○	○	○	○

Note 1: To reset the motion indication, press the button on the front of protection relay

Note 2: The contact will turn off after 500 ms or more. Use a self-hold circuit.

Note 3: Only one function can be selected from OH, NS, REF or trip indication.

Selection of two or more functions involves manual connection of their control circuits (custom configuration). Contact Terasaki for details.

Note 4: Only one function can be selected from PTA2, UV or spring charge indication.

Selection of two or more functions involves manual connection of their control circuits (custom configuration). Contact Terasaki for details.

Note 5: Motion indication contacts are commonly used for ST and INST/MCR.

※1: A switch is used to indicate the ACB has been tripped. This switch is activated whenever the off button, the overcurrent trip device, shunt trip device or undervoltage trip device is activated.

### 3 Contact ratings for Operation indication

Voltage (V)		Current (A)			
		[1] Single Contact		[2] Individual contacts	
		Resistive load	Inductive load	Resistive load	Inductive load
AC	250	3	3	0.5	0.2
	250	0.3	0.15	0.27	0.04
DC	125	0.5	0.25	0.5	0.2
	30	3	3	2	0.7

## Protection relay with advanced L.C.D. display type AGR-31B (contact Terasaki for details)

### 1 Monitoring various data on L.C.D.

Protection relay can monitor:

- Phase current (A) of I<sub>1</sub>, I<sub>2</sub>, I<sub>3</sub> and their max. peak current
- Current (A) of I<sub>n</sub>, I<sub>g</sub>
- Line voltage (V) of V<sub>12</sub>, V<sub>23</sub>, V<sub>31</sub> and their max peak voltage (or Phase voltage (V) of V<sub>1N</sub>, V<sub>2N</sub>, V<sub>3N</sub> and their peak voltage
- Harmonics
- Active power (W/kw)
- Power factor (cos  $\theta$ )
- Electrical energy (Wh/ kWh/ MWh/ GWh)
- Frequency (Hz)
- Trip history

Fault current is monitored, and the operation cause is indicated on LCD and via individual contacts.

Note 1: The supply voltage to the Protection relay for indicating the main circuit voltage or power must not exceed 250VAC, a step-down power transformer is needed. When ordering the ACB, state the step-down ratio of the transformer you will use.

Note 2: Special version without requiring step-down transformer is applicable in the main circuit voltage range from 250 to 690 VAC using the built-in register circuit board. To request the version without a step-down transformer, specify your main circuit voltage.

### 2 Gives the system alarm with number on the LCD for the following abnormal function.

- Trip function fail
- MHT circuit break





## Protection Relay Selection Table

Protection characteristic	<b>Protection Relay</b>		PROTECTION						FUNCTIONS				
			Standard Protection			Ground Fault ④		N-Phase	Indication and Monitoring				
			Long Time	Short Time	Instantaneous/MCR	Unrestricted	Restricted	N-phase Protection	Indication		Monitoring		
			LT	ST	INST	MCR	UREF	REF ②	NP	Single Contact	Individual Contacts	Ammeter	Energy Analyser H
<b>Standard Protection Relays</b>													
Dial Type	For general feeder circuits	AGR-11BL-AL	●	●	---	-----	-----	○	●	-----	-----	-----	
		AGR-11BL-GL	●	●	---	●	-----	○	●	-----	-----	-----	
		AGR-11BL-AS (manual reset optional)	●	●	---	-----	-----	○	●	-----	-----	-----	
		AGR-11BL-GS (manual reset optional)	●	●	---	●	-----	○	●	-----	-----	-----	
Standard LCD Type	For general feeder circuits	AGR-21BL-PS	●	●	●	-----	-----	○	-----	●	●	-----	
		AGR-21BL-PG	●	●	●	●	○	○	-----	●	●	-----	
<b>Specialised Protection Relays</b>													
Standard LCD Type	① IEC 60255-3	AGR-21BR-PS	●	●	●	-----	-----	○	-----	●	●	-----	
		AGR-21BR-PG	●	●	●	●	○	○	-----	●	●	-----	
	For generator protection	AGR-21BS-PS	●	●	●	-----	-----	-----	-----	●	●	-----	
		AGR-22BS-PR	●	●	●	-----	-----	-----	-----	●	●	-----	
	Enhanced LCD Type	For general feeder circuits	AGR-31BL-PS-H	●	●	●	-----	-----	○	-----	●	●	●
			AGR-31BL-PG-H	●	●	●	●	○	○	-----	●	●	●
① IEC 60255-3		AGR-31BR-PS-H	●	●	●	-----	-----	○	-----	●	●	●	
		AGR-31BR-PG-H	●	●	●	●	○	○	-----	●	●	●	
For generator protection	AGR-31BS-PS-H	●	●	●	-----	-----	-----	-----	●	●	●		
	AGR-31BS-PR-H	●	●	●	-----	-----	-----	-----	●	●	●		

Back Lit option available for AGR-21B

- : Available as standard
- : Available as option
- : Not available

- ① : Standard Inverse, Very Inverse, Extremely Inverse Curves
- ② : Only one function can be selected from OH, NS, REF or trip indication. Selection of two or more functions involves manual connection of their control circuits (special specification). Contact Terasaki for details.
- ③ : Only one function can be selected from PTA2, UV, V or spring charge indication. Selection of two or more functions involves manual connection of their control circuits (special specification). Contact Terasaki for details.

- ④ : Not available if CT rated primary current [ $I_{CT}$ ] is 400A or less.
- ⑤ : Available up to 3,200A rated current [ $I_n$ ].
- ⑥ : Over AC 250V, a step down VT is required.

For full operational information see pages 37 to 40

Note: When a protection function of AGR-11B protection relay with single contact indication is activated, the corresponding operation LED indicators is ON momentarily or OFF. However the LED indicator is kept ON when the protection function is checked with the optional protection relay checker.



# Protection Relays



## SPECIAL APPLICATIONS

Contact Temperature Monitoring <b>OH</b> ②	Zone Interlock <b>Z</b>	Earth Leakage Protection <b>ELT</b> ⑤	Reverse Power Protection <b>RPT</b> ⑥	Phase Rotation Protection <b>NS</b> ②	Under Voltage Alarm <b>UVA</b> ③	Over Voltage Alarm and Under/Over Frequency Protection <b>V</b> ③	Pre-Trip Alarm		Spring Charge Indication ③	Trip Indication ②	Communication <b>C</b>	Field Test	Control Power
							<b>PTA</b>	<b>PTA2</b> ③					
-----	-----	-----	-----	-----	-----	-----	-----	-----	○	○	-----	-----	Not Required
-----	-----	-----	-----	-----	-----	-----	-----	-----	○	○	-----	-----	Not Required
-----	-----	-----	-----	-----	-----	-----	-----	-----	○	○	-----	-----	Required
-----	-----	-----	-----	-----	-----	-----	-----	-----	○	○	-----	-----	Required
-----	-----	-----	-----	○	-----	-----	●	-----	○	○	○	●	Required
-----	-----	-----	-----	○	-----	-----	●	-----	○	○	○	●	Required
-----	-----	-----	-----	○	-----	-----	●	-----	○	○	○	●	Required
-----	-----	-----	-----	○	-----	-----	●	-----	○	○	○	●	Required
○	○	-----	●	-----	○	-----	●	○	○	○	○	●	Required
○	○	○	-----	○	○	○	●	-----	○	○	○	●	Required
○	○	-----	-----	○	○	○	●	-----	○	○	○	●	Required
○	○	○	-----	○	○	○	●	-----	○	○	○	●	Required
○	○	-----	-----	○	○	○	●	-----	○	○	○	●	Required
○	○	-----	-----	-----	○	○	●	○	○	○	○	●	Required
○	○	-----	●	-----	○	○	●	○	○	○	○	●	Required

3

If the control power is not supplied or is lost, each function operates as follows:

LT, ST, INST, RPT	Operates normally.
GF	Operates normally When the CT rated primary current [I <sub>CT</sub> ] is less than 800A and the GF pick-up current is set to 10 %, the GF becomes inoperative.
MCR	Operates as INST.
PTA	Is inoperative. 1-channel PTA 2-channel PTA
ELT	Is inoperative.
LED indicator on protection relay with single-contact indication	Is on momentarily or off.
Contact output from protection relay with single-contact indication	Turns off after 40 ms or more.
Contact output from protection relay with individual contact indication	Is inoperative.
LCD	Will display without backlit.
Field test facility	Is inoperative.



# Protection Relays

## L-characteristic for general feeder circuits (Type AGR-11BL, 21BL, 31BL)

### Protection functions

Adjustable long time-delay trip characteristics

**LT**

Pick-up current  $[I_R]$  (A)

Time-delay  $[t_R]$  (s)

Time-delay setting tolerance (%)

Adjustable short time-delay trip characteristics

**ST**

Pick-up current  $[I_{sd}]$  (A)

Current setting tolerance (%)

Time-delay  $[t_{sd}]$  (ms) Relay time

Resettable time (ms)

Max. total clearing time (ms)

Adjustable instantaneous trip characteristics

**INST** (AGR-11B) **INST/MCR** (AGR-21B)

**INST1/INST2/MCR** (AGR-31B)

Pick-up current  $[I]$  (A)

Current setting tolerance (%)

Adjustable pre-trip alarm characteristics

**PTA**

Pick-up current  $[I_{P1}]$  (A)

Current setting tolerance (%)

Time-delay  $[t_{P1}]$  (s)

Time-delay setting tolerance (%)

Adjustable ground fault trip characteristics

**GF**

Pick-up current  $[I_g]$  (A)

Current setting tolerance (%)

Time-delay  $[t_g]$  (ms) Relay time

Resettable time (ms)

Max. total clearing time (ms)

Ground fault trip characteristics on line side

**REF** (AGR-21B, 31B only)

Pick-up current  $[I_{REF}]$  (A)

current setting tolerance (%)

Time-delay (s)

N-phase protection characteristics

**NP**

Pick-up current  $[I_N]$  (A)

Time-delay  $[t_N]$  (s)

Time-delay setting tolerance (%)

Phase rotation protection characteristics

**NS** (AGR-21B, 31B only)

Pick-up current  $[I_{NS}]$  (A)

current setting tolerance (%)

Time-delay  $[t_{NS}]$  (s)

Time-delay setting tolerance (%)

Adjustable earth leakage trip characteristics

**ELT** (AGR-31B only)

Pick-up current  $[I_{AR}]$  (A)

Current setting tolerance

Time-delay  $[t_{AR}]$  (ms) Relay time

Resettable time (ms)

Max. total clearing time (ms)

Undervoltage alarm characteristics

**UV** (AGR-31B only)

Recovery setting voltage (V)

Recovery voltage setting tolerance (%)

Setting voltage (V)

Voltage setting tolerance (%)

Time-delay (s)

Time-delay setting tolerance (%)

Control power

### Setting range

$[I_n] \times (0.8 - 0.85 - 0.9 - 0.95 - 1.0 - \text{NON})$ ; except for AGR-31BL: 0.8 - 0.1 in steps of 0.01

• Non tripping when load current  $\leq ([I_R] \times 1.05)$ . • Tripping when  $([I_R] \times 1.05) < \text{load current} \leq ([I_R] \times 1.2)$

(0.5 - 1.25 - 2.5 - 5 - 10 - 15 - 20 - 25 - 30) at 600% of  $[I_R]$ ; 9 graduations

$\pm 15\% + 150\text{ms} - 0\text{ms}$

$[I_n] \times (1 - 1.5 - 2 - 2.5 - 3 - 4 - 6 - 8 - 10 - \text{NON})$ ; 10 graduations

$\pm 15\%$

50	100	200	400	600	800
25	75	175	375	575	775

; 6 graduations

25

120

170

270

470

670

870

$[I_n] \times (2 - 4 - 6 - 8 - 10 - 12 - 14 - 16 - \text{NON})$ ; 9 graduations

$\pm 20\%$

$[I_n] \times (0.75 - 0.8 - 0.85 - 0.9 - 0.95 - 1.0)$ ; 6 graduations

$\pm 7.5\%$

(5 - 10 - 15 - 20 - 40 - 60 - 80 - 120 - 160 - 200) at  $[I_{P1}]$  or more; 10 graduations

$\pm 15\% + 100\text{ms} - 0\text{ms}$

Note: Set  $[I_g]$  to 1200A or less.

$[I_{CT}] \times (0.1 - 0.2 - 0.3 - 0.4 - 0.6 - 0.8 - 1.0 - \text{NON})$ ; 8 graduations

$\pm 20\%$

100	200	300	500	1000	2000
75	175	275	475	975	1975

; 6 graduations

75

170

270

370

570

1070

2070

$[I_{CT}] \times (0.1 - 0.2 - 0.3 - 0.4 - 0.6 - 0.8 - 1.0 - \text{NON})$ ; 8 graduations

$\pm 20\%$

Inst

$[I_{CT}] \times (0.4 - 0.5 - 0.63 - 0.8 - 1.0)$ ; Factory set to a user-specified value for AGR-11BL.

• Non tripping when load current  $\leq ([I_N] \times 1.05)$ . • Tripping when  $([I_N] \times 1.05) < \text{load current} \leq ([I_N] \times 1.2)$

Tripping at 600% of  $[I_N]$  with **LT** time-delay  $[t_R]$

$\pm 15\% + 150\text{ms} - 0\text{ms}$

$[I_n] \times (0.2 - 0.3 - 0.4 - 0.5 - 0.6 - 0.7 - 0.8 - 0.9 - 1.0)$ ; 9 graduations

$\pm 10\%$

(0.4 - 0.8 - 1.2 - 1.6 - 2 - 2.4 - 2.8 - 3.2 - 3.6 - 4) at 150% of  $[I_{NS}]$ ; 10 graduations

$\pm 20\% + 150\text{ms} - 0\text{ms}$

0.2 - 0.3 - 0.5 (Medium sensitivity) or 1 - 2 - 3 - 5 - 10 (Low sensitivity)

Non operate below 70% of  $[I_{AR}]$ , Operate between 70% and 100% of  $[I_{AR}]$ .

100	150	300	500	800	1500	3000
50	100	250	450	750	1450	2950

; 7 graduations

50

250

300

450

650

950

1650

3150

$[V_n] \times (0.8 - 0.85 - 0.9 - 0.95)$ ; 4 graduations

$\pm 5\%$

$[V_n] \times (0.4 - 0.6 - 0.8)$ ; 3 graduations

$\pm 5\%$

0.1 - 0.5 - 1 - 2 - 5 - 10 - 15 - 20 - 30 - 36; 10 graduations

$\pm 15\% + 100\text{ms} - 0\text{ms}$

AC100 - 120V ) Common DC100 - 125V ) Common DC24V ) Common

AC200 - 240V ) Common DC200 - 250V ) Common DC48V ) Common

Power consumption: 5 VA

\_: Default setting. Note: AGR-31B allows fine adjustment settings.



# Protection Relays

## Protection functions

Over voltage alarm

V (AGR-31B only)

Voltage setting

Time setting

## Under/Over Frequency Protections (UFOF)

Under-frequency threshold  $[F_{uf}]$

Time delay  $[t_{uf}]$

Over-frequency threshold  $[F_{of}]$

Time delay  $[t_{of}]$

Mode

## Setting range

$[V_n] \times (105\% \text{ to } 150\%) V$ , Tolerance:  $\pm 5\% * 1\%$  step

(0.1 to 5.0) (sec) at voltage setting or less, Tolerance:  $\pm 15\%$ , +0.1s-0s \*0.1 sec step

$[F_n] \times (80\% \text{ to } 105\%) V$ , \*1% step

(0.1 to 10) (sec) \*0.1 sec step

$[F_n] \times (95\% \text{ to } 140\%) V$ , \*1% step

(0.1 to 10) (sec) \*0.1 sec step

TRIP/AL/OFF

## Values of $[I_{CT}]$ and $[I_n]$

Type	Applicable $[I_{CT}]$ (A)	Rated current $[I_n]$ (A)				
		$\times 0.5$	$\times 0.63$	$\times 0.8$	$\times 1.0$	$\times 1.0$
AR208S	200	100	125	160	200	
	400	200	250	320	400	
	800	400	500	630	800	
AR212S	400	200	250	320	400	
	800	400	500	630	800	
	1000	500	630	800	1000	
	1250	630	800	1000	1250	
AR216S	400	200	250	320	400	
	800	400	500	630	800	
	1000	500	630	800	1000	
	1250	630	800	1000	1250	
	1600	800	1000	1250	1600	

Type	Applicable $[I_{CT}]$ (A)	Rated current $[I_n]$ (A)				
		$\times 0.5$	$\times 0.63$	$\times 0.8$	$\times 1.0$	$\times 1.0$
AR220S	400	200	250	320	400	
	800	400	500	630	800	
	1000	500	630	800	1000	
	1250	630	800	1000	1250	
	1600	800	1000	1250	1600	
	2000	1000	1250	1600	2000	
AR325S	2500	1250	1600	2000	2500	
AR332S	3200	1600	2000	2500	3200	
AR440SB	4000	2000	2500	3200	4000	
AR440S	4000	2000	2500	3200	4000	
AR650S	5000	2500	3200	4000	5000	
AR663S	6300	3200	4000	5000	6300	

Type	Applicable $[I_{CT}]$ (A)	Rated current $[I_n]$ (A)				
		$\times 0.5$	$\times 0.63$	$\times 0.8$	$\times 1.0$	$\times 1.0$
AR212H	200	100	125	160	200	
	400	200	250	320	400	
	800	400	500	630	800	
	1000	500	630	800	1000	
	1250	630	800	1000	1250	
AR216H	1600	800	1000	1250	1600	
AR220H	2000	1000	1250	1600	2000	
AR316H	200	100	125	160	200	
	400	200	250	320	400	
AR420H	800	400	500	630	800	
	1250	630	800	1000	1250	
	1600	800	1000	1250	1600	
AR320H	2000	1000	1250	1600	2000	
AR325H	2500	1250	1600	2000	2500	
AR332H	3200	1600	2000	2500	3200	
AR440H	4000	2000	2500	3200	4000	
	5000	2500	3200	4000	5000	
AR663H	6300	3200	4000	5000	6300	

## Protection characteristics

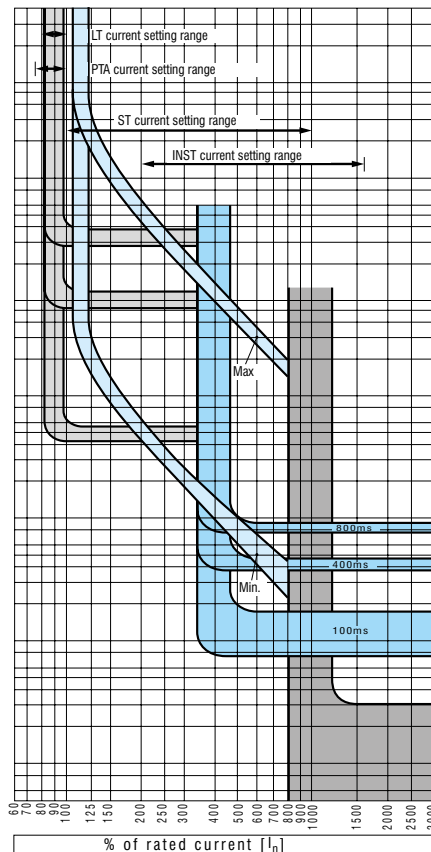
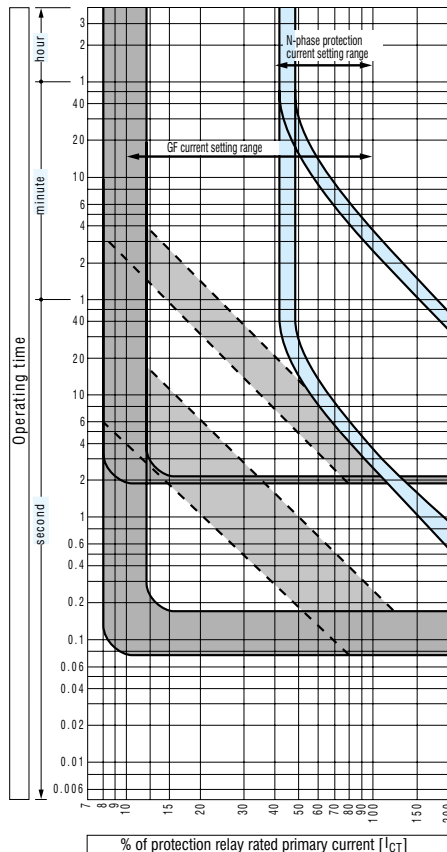

The ST trip characteristic shown in the figure applies when the ramp characteristic select switch is in the OFF position.

Note: Total breaking time for AR6 is 0.05sec.



## R-characteristic for general feeder circuits (Type AGR-21BR, 31BR)

Protection functions	Setting range																					
<ul style="list-style-type: none"> <li>Adjustable long time-delay trip characteristics</li> </ul>	Select one from among $I^{0.02t}$ , $I_t$ , $I^{2t}$ , $I^{3t}$ , and $I^{4t}$ on LCD.																					
<b>LT</b>																						
Pick-up current [ $I_R$ ] (A)	$[I_R] \times (0.8 - 0.85 - 0.9 - 0.95 - 1.0 - \text{NON})$ ; except for AGR-31BR: 0.8 - 1 in steps of 0.01																					
Current setting tolerance (%)	$\pm 5\%$																					
Time-delay [ $t_R$ ] (s)	$(1 - 2 - 3 - 4 - 5 - 6.3 - 6.8 - 10)$ at 300% of [ $I_R$ ]; 8 graduations																					
Time-delay setting tolerance (%)	$\pm 20\% + 150\text{ms} - 0\text{ms}$																					
<ul style="list-style-type: none"> <li>Adjustable short time-delay trip characteristics</li> </ul>																						
<b>ST</b>																						
Pick-up current [ $I_{sg}$ ] (A)	$[I_{sg}] \times (1 - 1.5 - 2 - 2.5 - 3 - 4 - 6 - 8 - 10 - \text{NON})$ ; 10 graduations																					
Current setting tolerance (%)	$\pm 15\%$																					
Time-delay [ $t_{sd}$ ] (ms) Relay time	<table border="1"> <tr> <td>50</td><td>100</td><td>200</td><td>400</td><td>600</td><td>800</td> </tr> <tr> <td>25</td><td>75</td><td>175</td><td>375</td><td>575</td><td>775</td> </tr> <tr> <td>120</td><td>170</td><td>270</td><td>470</td><td>670</td><td>870</td> </tr> </table> ; 6 graduations	50	100	200	400	600	800	25	75	175	375	575	775	120	170	270	470	670	870			
50	100	200	400	600	800																	
25	75	175	375	575	775																	
120	170	270	470	670	870																	
Resettable time (ms)																						
Max. total clearing time (ms)																						
<ul style="list-style-type: none"> <li>Adjustable instantaneous trip characteristics</li> </ul>																						
<b>INST</b> (AGR-11B) <b>INST/MCR</b> (AGR-21B)																						
<b>INST1/INST2/MCR</b> (AGR-31B)																						
Pick-up current [ $I_i$ ] (A)	$[I_i] \times (2 - 4 - 6 - 8 - 10 - 12 - 14 - 16 - \text{NON})$ ; 9 graduations																					
Current setting tolerance (%)	$\pm 20\%$																					
<ul style="list-style-type: none"> <li>Adjustable pre-trip alarm characteristics</li> </ul>																						
<b>PTA</b>																						
Pick-up current [ $I_{P1}$ ] (A)	$[I_{P1}] \times (0.75 - 0.8 - 0.85 - 0.9 - 0.95 - 1.0)$ ; 6 graduations																					
Current setting tolerance (%)	$\pm 7.5\%$																					
Time-delay [ $t_{P1}$ ] (s)	$(5 - 10 - 15 - 20 - 40 - 60 - 80 - 120 - 160 - 200)$ at [ $I_{P1}$ ] or more; 10 graduations																					
Time-delay setting tolerance (%)	$\pm 15\% + 100\text{ms} - 0\text{ms}$																					
<ul style="list-style-type: none"> <li>Adjustable ground fault trip characteristics</li> </ul>																						
<b>GF</b>																						
Pick-up current [ $I_g$ ] (A)	Note: Set [ $I_g$ ] to 1200A or less.																					
Current setting tolerance (%)	$[I_{CT}] \times (0.1 - 0.2 - 0.3 - 0.4 - 0.6 - 0.8 - 1.0 - \text{NON})$ ; 8 graduations																					
Time-delay [ $t_g$ ] (ms) Relay time	<table border="1"> <tr> <td>100</td><td>200</td><td>300</td><td>500</td><td>1000</td><td>2000</td> </tr> <tr> <td>75</td><td>175</td><td>275</td><td>475</td><td>975</td><td>1975</td> </tr> <tr> <td>170</td><td>270</td><td>370</td><td>570</td><td>1070</td><td>2070</td> </tr> </table> ; 6 graduations	100	200	300	500	1000	2000	75	175	275	475	975	1975	170	270	370	570	1070	2070			
100	200	300	500	1000	2000																	
75	175	275	475	975	1975																	
170	270	370	570	1070	2070																	
Resettable time (ms)																						
Max. total clearing time (ms)																						
<ul style="list-style-type: none"> <li>Ground fault trip characteristics on line side</li> </ul>																						
<b>REF</b>																						
Pick-up current [ $I_{REF}$ ] (A)	$[I_{CT}] \times (0.1 - 0.2 - 0.3 - 0.4 - 0.6 - 0.8 - 1.0 - \text{NON})$ ; 8 graduations																					
current setting tolerance (%)	$\pm 20\%$																					
Time-delay (s)	Inst																					
<ul style="list-style-type: none"> <li>N-phase protection characteristics</li> </ul>																						
<b>NP</b>																						
Pick-up current [ $I_N$ ] (A)	$[I_{CT}] \times (0.4 - 0.5 - 0.63 - 0.8 - 1.0)$ ; Factory set to a user-specified value for AGR-11BR.																					
Current setting tolerance (%)	$\pm 5\%$																					
Time-delay [ $t_N$ ] (s)	Tripping at 300% of [ $I_N$ ] with <b>LT</b> time-delay [ $t_R$ ]																					
Time-delay setting tolerance (%)	$\pm 20\% + 150\text{ms} - 0\text{ms}$																					
<ul style="list-style-type: none"> <li>Phase rotation protection characteristics</li> </ul>																						
<b>NS</b>																						
Pick-up current [ $I_{NS}$ ] (A)	$[I_{NS}] \times (0.2 - 0.3 - 0.4 - 0.5 - 0.6 - 0.7 - 0.8 - 0.9 - 1.0)$ ; 9 graduations																					
current setting tolerance (%)	$\pm 10\%$																					
Time-delay [ $t_{NS}$ ] (s)	$(0.4 - 0.8 - 1.2 - 1.6 - 2 - 2.4 - 2.8 - 3.2 - 3.6 - 4)$ at 150% of [ $I_{NS}$ ] ; 10 graduations																					
Time-delay setting tolerance (%)	$\pm 20\% + 150\text{ms} - 0\text{ms}$																					
<ul style="list-style-type: none"> <li>Adjustable earth leakage trip characteristics</li> </ul>																						
<b>ELT</b> (AGR-31B only)																						
Pick-up current [ $I_{AR}$ ] (A)	0.2 - 0.3 - 0.5 (Medium sensitivity) or 1 - 2 - 3 - 5 - 10 (Low sensitivity)																					
Current setting tolerance	Non operate below 70% of [ $I_{AR}$ ], Operate between 70% and 100% of [ $I_{AR}$ ].																					
Time-delay [ $t_{AR}$ ] (ms) Relay time	<table border="1"> <tr> <td>100</td><td>150</td><td>300</td><td>500</td><td>800</td><td>1500</td><td>3000</td> </tr> <tr> <td>50</td><td>100</td><td>250</td><td>450</td><td>750</td><td>1450</td><td>2950</td> </tr> <tr> <td>250</td><td>300</td><td>450</td><td>650</td><td>950</td><td>1650</td><td>3150</td> </tr> </table> ; 7 graduations	100	150	300	500	800	1500	3000	50	100	250	450	750	1450	2950	250	300	450	650	950	1650	3150
100	150	300	500	800	1500	3000																
50	100	250	450	750	1450	2950																
250	300	450	650	950	1650	3150																
Resettable time (ms)																						
Max. total clearing time (ms)																						
<ul style="list-style-type: none"> <li>Undervoltage alarm characteristics</li> </ul>																						
<b>UV</b> (AGR-31B only)																						
Recovery setting voltage (V)	$[V_n] \times (0.8 - 0.85 - 0.9 - 0.95)$ ; 4 graduations																					
Recovery voltage setting tolerance (%)	$\pm 5\%$																					
Setting voltage (V)	$[V_n] \times (0.4 - 0.6 - 0.8)$ ; 3 graduations																					
Voltage setting tolerance (%)	$\pm 5\%$																					
Time-delay (s)	0.1 - 0.5 - 1 - 2 - 5 - 10 - 15 - 20 - 30 - 36 ; 10 graduations																					
Time-delay setting tolerance (%)	$\pm 15\% + 100\text{ms} - 0\text{ms}$																					
<ul style="list-style-type: none"> <li>Control power</li> </ul>	AC100 - 120V ) Common DC100 - 125V ) Common DC24V ) Common AC200 - 240V ) Common DC200 - 250V ) Common DC48V ) Common																					
	Power consumption: 5 VA																					

\_: Default setting. Note: AGR-31B allows fine adjustment settings.



# Protection Relays

## Protection functions

Over voltage alarm

V (AGR-31B only)

Voltage setting

Time setting

Under/Over Frequency Protections (UFOF)

Under-frequency threshold  $[F_{uf}]$

Time delay  $[t_{uf}]$

Over-frequency threshold  $[F_{of}]$

Time delay  $[t_{of}]$

Mode

## Setting range

$[V_n] \times (105\% \text{ to } 150\%) V$ , Tolerance:  $\pm 5\% * 1\%$  step

(0.1 to 5.0) (sec) at voltage setting or less, Tolerance:  $\pm 15\%$ ,  $+0.1s-0s * 0.1$  sec step

$[F_n] \times (80\% \text{ to } 105\%) V$ ,  $* 1\%$  step

(0.1 to 10) (sec)  $* 0.1$  sec step

$[F_n] \times (95\% \text{ to } 140\%) V$ ,  $* 1\%$  step

(0.1 to 10) (sec)  $* 0.1$  sec step

TRIP/AL/OFF

## Values of $[I_{CT}]$ and $[I_n]$

Type	Applicable $[I_{CT}]$ (A)	Rated current $[I_n]$ (A)			
		$\times 0.5$	$\times 0.63$	$\times 0.8$	$\times 1.0$
AR208S	200	100	125	160	200
	400	200	250	320	400
	800	400	500	630	800
AR212S	400	200	250	320	400
	800	400	500	630	800
	1000	500	630	800	1000
	1250	630	800	1000	1250
AR216S	400	200	250	320	400
	800	400	500	630	800
	1000	500	630	800	1000
	1250	630	800	1000	1250
	1600	800	1000	1250	1600

Type	Applicable $[I_{CT}]$ (A)	Rated current $[I_n]$ (A)			
		$\times 0.5$	$\times 0.63$	$\times 0.8$	$\times 1.0$
AR220S	400	200	250	320	400
	800	400	500	630	800
	1000	500	630	800	1000
	1250	630	800	1000	1250
	1600	800	1000	1250	1600
	2000	1000	1250	1600	2000
AR325S	2500	1250	1600	2000	2500
AR332S	3200	1600	2000	2500	3200
AR440SB	4000	2000	2500	3200	4000
AR440S	4000	2000	2500	3200	4000
AR650S	5000	2500	3200	4000	5000
AR663S	6300	3200	4000	5000	6300

Type	Applicable $[I_{CT}]$ (A)	Rated current $[I_n]$ (A)			
		$\times 0.5$	$\times 0.63$	$\times 0.8$	$\times 1.0$
AR212H	200	100	125	160	200
	400	200	250	320	400
	800	400	500	630	800
	1000	500	630	800	1000
	1250	630	800	1000	1250
AR216H	1600	800	1000	1250	1600
AR220H	2000	1000	1250	1600	2000
AR316H	200	100	125	160	200
	400	200	250	320	400
	800	400	500	630	800
AR320H	1250	630	800	1000	1250
	1600	800	1000	1250	1600
	2000	1000	1250	1600	2000
	2500	1250	1600	2000	2500
	3200	1600	2000	2500	3200
AR420H	800	400	500	630	800
	2000	1000	1250	1600	2000
AR440H	4000	2000	2500	3200	4000
AR663H	5000	2500	3200	4000	5000
	6300	3200	4000	5000	6300

## Protection characteristics

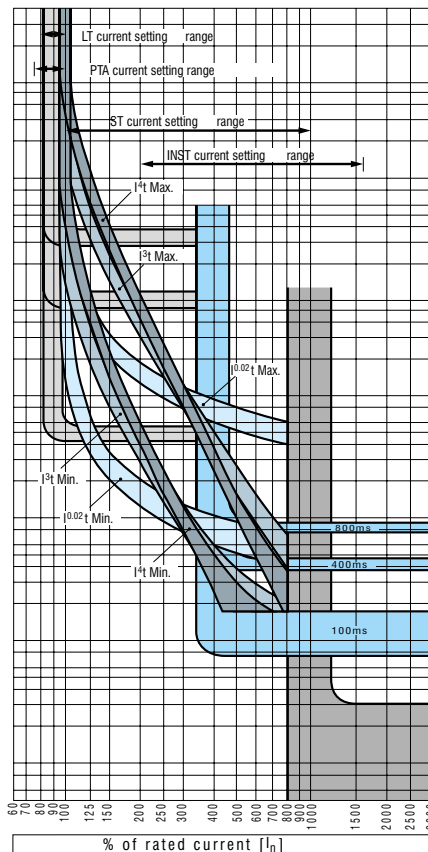
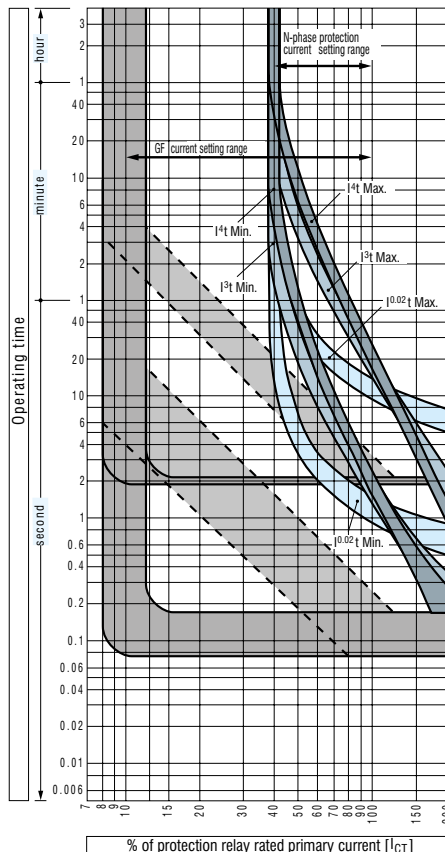

The ST trip characteristic shown in the figure applies when the ramp characteristic select switch is in the OFF position.

Note: Total breaking time for AR6 is 0.05sec.



## S-characteristic for general feeder circuits (Type AGR-21BS, 22BS, 31BS)

Protection functions	
■ Adjustable long time-delay trip characteristics	
LT	
Pick-up current [ $I_R$ ] (A)	
Current setting tolerance (%)	
Time-delay [ $t_R$ ] (s)	
Time-delay setting tolerance (%)	
■ Adjustable short time-delay trip characteristics	
ST	
Pick-up current [ $I_{sd}$ ] (A)	
Current setting tolerance (%)	
Time-delay [ $t_{sd}$ ] (ms) Relay time	
Resettable time (ms)	
Max. total clearing time (ms)	
■ Adjustable instantaneous trip characteristics	
INST (AGR-11B)	INST/MCR (AGR-21B)
INST1/INST2/MCR (AGR-31B)	
Pick-up current [ $I_i$ ] (A)	
Current setting tolerance (%)	
■ Adjustable pre-trip alarm characteristics	
PTA	
Pick-up current [ $I_{p1}$ ] (A)	
Current setting tolerance (%)	
Time-delay [ $t_{p1}$ ] (s)	
Time-delay setting tolerance (%)	
PTA 2 (AGR-22B, 31B only)	
Pick-up current [ $I_{p2}$ ] (A)	
Current setting tolerance (%)	
Time-delay [ $t_{p2}$ ] (s)	
Time-delay setting tolerance (%)	
■ Adjustable reverse power trip characteristics	
RPT (AGR-22B, 31B only)	
Pick-up power [ $P_R$ ] (kW)	
Power setting tolerance (%)	
Time-delay [time] (s)	
Time-delay setting tolerance (%)	
■ Undervoltage alarm characteristics	
UV (AGR-22B, 31B only)	
Recovery setting voltage (V)	
Recovery voltage setting tolerance (%)	
Setting voltage (V)	
Voltage setting tolerance (%)	
Time-delay (s)	
Time-delay setting tolerance (%)	
■ Control power	
Over voltage alarm	
V (AGR-31B only)	
Voltage setting	
Time setting	
■ Under/Over Frequency Protections (UFOF)	
Under-frequency threshold	$[F_{uf}]$
Time delay	$[t_{uf}]$
Over-frequency threshold	$[F_{of}]$
Time delay	$[t_{of}]$
Mode	

Setting range						
$[I_n] \times (0.8 - 1.0 - 1.05 - 1.1 - 1.15 - \text{NON})$ ; 6 graduations						
$\pm 5\%$						
$(15 - 20 - 25 - 30 - 40 - 50 - 60)$ at 120% of $[I_R]$ ; 7 graduations						
$\pm 15\% + 150\text{ms} - 0\text{ms}$						
$[I_n] \times (2 - 2.5 - 2.7 - 3 - 3.5 - 4 - 4.5 - 5 - \text{NON})$ ; 9 graduations						
$\pm 10\%$						
100	200	300	400	600	800	6 graduations
75	175	275	375	575	775	
170	270	370	470	670	870	
$[I_n] \times (2 - 4 - 6 - 8 - 10 - 12 - 14 - 16 - \text{NON})$ ; 9 graduations						
$\pm 20\%$						
$[I_n] \times (0.75 - 0.8 - 0.85 - 0.9 - 0.95 - 1.0 - 1.05)$ ; 7 graduations						
$\pm 5\%$						
$(10 - 15 - 20 - 25 - 30)$ at 120% of $[I_{p1}]$ ; 5 graduations						
$\pm 15\% + 100\text{ms} - 0\text{ms}$						
$[I_n] \times (0.75 - 0.8 - 0.85 - 0.9 - 0.95 - 1.0 - 1.05)$ ; 7 graduations						
$\pm 5\%$						
$1.5 \times [I_{p1}]$ at 120% of $[I_{p2}]$						
$\pm 15\% + 100\text{ms} - 0\text{ms}$						
Rated power $[P_n] \times (0.04 - 0.05 - 0.06 - 0.07 - 0.08 - 0.09 - 0.1 - \text{NON})$ ; 8 graduations						
$+0 - 20\%$						
$(2.5 - 5 - 7.5 - 10 - 12.5 - 15 - 17.5 - 20)$ at 100% of $[P_R]$ ; 8 graduations						
$\pm 20\%$						
$[V_n] \times (0.8 - 0.85 - 0.9 - 0.95)$ ; 4 graduations						
$\pm 5\%$						
$[V_n] \times (0.4 - 0.6 - 0.8)$ ; 3 graduations						
$\pm 5\%$						
$0.1 - 0.5 - 1 - 2 - 5 - 10 - 15 - 20 - 30 - 36$ ; 10 graduations						
$\pm 15\% + 100\text{ms} - 0\text{ms}$						
AC100 - 120V	) Common	DC100 - 125V	) Common	DC24V	) Common	
AC200 - 240V		DC200 - 250V		DC48V		
Power consumption: 5 VA						
$[V_n] \times (105\% \text{ to } 150\%) \text{ V}$ , Tolerance: $\pm 5\% * 1\%$ step						
$(0.1 \text{ to } 5.0)$ (sec) at voltage setting or less, Tolerance: $\pm 15\%$ , $+0.1\text{s} - 0\text{s} * 0.1 \text{ sec step}$						
$[F_n] \times (80\% \text{ to } 105\%) \text{ V}$ , *1% step						
$(0.1 \text{ to } 10)$ (sec) *0.1 sec step						
$[F_n] \times (95\% \text{ to } 140\%) \text{ V}$ , *1% step						
$(0.1 \text{ to } 10)$ (sec) *0.1 sec step						
TRIP/AL/OFF						

\_: Default setting. Note: AGR-31B allows fine adjustment settings.



## Applicable range of generator rated current [ $I_n$ ]

Type	protection relay rated primary current [ $I_{CT}$ ] (A)	Applicable range of generator rated current [ $I_n$ ] (A)
AR208S	200	$100 \leq I_n \leq 200$
	400	$200 < I_n \leq 400$
	800	$400 < I_n \leq 800$
AR212S	400	$200 \leq I_n \leq 400$
	800	$400 < I_n \leq 800$
	1000	$500 < I_n \leq 1000$
AR216S	400	$200 \leq I_n \leq 400$
	800	$400 < I_n \leq 800$
	1000	$500 < I_n \leq 1000$
AR212S	1250	$630 < I_n \leq 1250$
	1600	$800 \leq I_n \leq 1600$
	2000	$1000 \leq I_n \leq 2000$
AR220S	400	$200 \leq I_n \leq 400$
	800	$400 < I_n \leq 800$
	1000	$500 < I_n \leq 1000$
	1250	$630 < I_n \leq 1250$
	1600	$800 \leq I_n \leq 1600$
AR325S	2500	$1250 \leq I_n \leq 2500$
	3200	$1600 \leq I_n \leq 3200$
AR440S	4000	$2000 \leq I_n \leq 4000$
	5000	$2500 \leq I_n \leq 5000$
AR663S	6300	$3200 \leq I_n \leq 6300$

Type	protection relay rated primary current [ $I_{CT}$ ] (A)	Applicable range of generator rated current [ $I_n$ ] (A)
AR212H	200	$100 \leq I_n \leq 200$
	400	$200 < I_n \leq 400$
	800	$400 < I_n \leq 800$
	1000	$500 < I_n \leq 1000$
AR216H	1250	$630 < I_n \leq 1250$
	1600	$800 \leq I_n \leq 1600$
AR220H	2000	$1000 \leq I_n \leq 2000$
AR316H	200	$100 \leq I_n \leq 200$
	400	$200 < I_n \leq 400$
	800	$400 < I_n \leq 800$
	1250	$630 < I_n \leq 1250$
	1600	$800 < I_n \leq 1600$
AR320H	2000	$1000 \leq I_n \leq 2000$
AR325H	2500	$1250 \leq I_n \leq 2500$
AR332H	3200	$1600 \leq I_n \leq 3200$
AR420H	800	$400 \leq I_n \leq 800$
	2000	$1000 \leq I_n \leq 2000$
AR440H	4000	$2000 \leq I_n \leq 4000$
AR663H	5000	$2500 \leq I_n \leq 5000$
	6300	$3200 \leq I_n \leq 6300$

## Protection characteristics

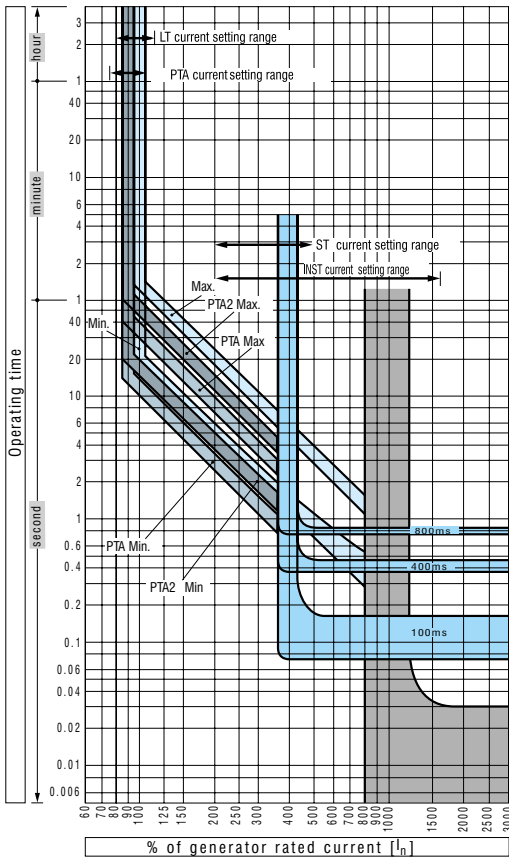

The ST trip characteristic shown in the figure applies when the ramp characteristic select switch is in the OFF position.

Note: Total breaking time for AR6 is 0.05sec.

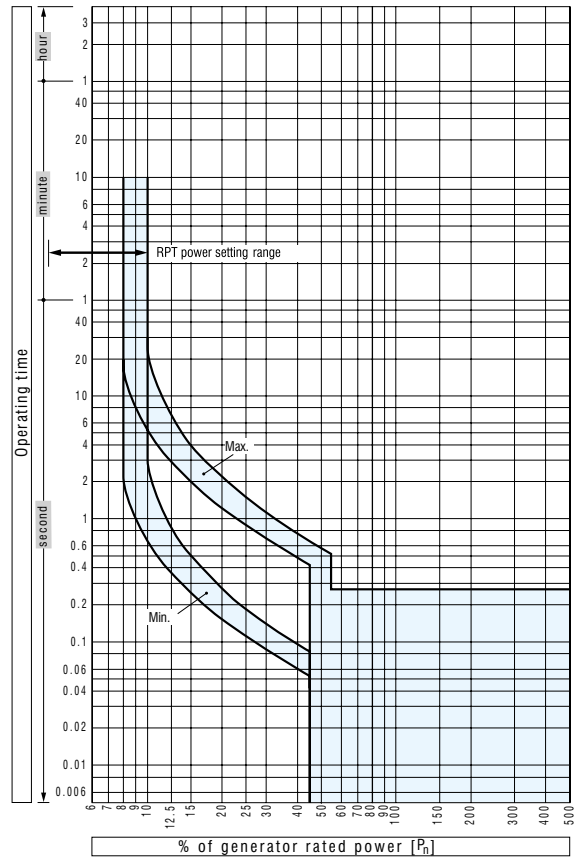



## Other Accessories

### Protection relay checker, type ANU-1

The Protection relay checker allows easy checking of the long-time delay trip, short time-delay trip, instantaneous trip, ground fault trip functions and the pre-trip alarm function of the Protection relay in the field.

#### Ratings and Specifications

<b>Power Supply</b>	AC100-240V; 50/60Hz with type C plug 4 x AA alkaline cells
<b>Power Consumption</b>	7VA
<b>Dimensions</b>	101 (W) x 195 (H) x 44 (D) mm
<b>Weight</b>	400g



#### Measurement output

- Long time delay trip pickup current
- Long time delay trip pickup time
- Short time delay trip pickup current
- Short time delay trip pickup time
- Instantaneous trip pickup current
- MCR trip pickup current
- Ground fault trip pickup current
- Ground fault trip pickup time
- N-phase protection trip pickup current
- N-phase protection trip pickup time
- Pre-trip alarm pickup current
- Pre-trip alarm pickup time

### Protection relay checker, type ANU-2

Protection relay test interface unit ANU-2 is a testing tool designed for checking the functionality of type AGR Protection relay (overcurrent release). Using this tool in conjunction with a commercial constant-current generator allows easy on-site testing of the Protection relay. The reverse power trip function of the protection relay can also be tested using the tool.

Protection relay test interface unit ANU-2 is a device that converts current into voltage. In addition to the unit, a constant-current generator is needed to test the Protection relay. Use a generator with a continuous rating of 5A (50/60 Hz) and a short-time rating of 50A (50/60 Hz) for 10 seconds (500 VA).



#### Ratings and Specifications

<b>Power Supply</b>	Input	External power supply (through power cable with AC adapter) 100 to 240V AC 50/60Hz)
	Output	9V DC
<b>Power Consumption</b>	7VA	
<b>Dimensions</b>	W160 x H90 x D220 (mm)	
<b>Weight</b>	2kg	

#### Measurement Output

- Long time delay trip pickup current
- Short time delay trip pickup current
- Instantaneous trip pickup current \*1
- Instantaneous trip operation
- MCR trip pickup current \*1
- Ground fault trip pickup current
- N-phase protection trip pickup current
- Pre-trip alarm pickup current \*2
- Reverse power protection trip pickup current \*4
- Long time delay trip pickup time simplified testing \*3
- Reverse power protection trip pickup time (simplified testing) \*3 \*4
- Pre-trip alarm pickup time (simplified testing) \*3

#### Accessories

- Power cable with AC adaptor (2m)
- Plug adaptor
- Signal cable (3m)
- Operation manual

\*1 Can be measured only when the input current does not exceed 50A

\*2 Not applicable for types AGR-11 or AGR-11B

\*3 A stopwatch is requirement for measurement

\*4 Applicable for types AGR-22BS-PR and AGR-31BS-PR only.



## Current transformer for neutral line (separate type)

When using a 3-pole ACB with the ground fault protection function to protect a 3-phase, 4-wire system against ground fault, install an appropriate current transformer (CT) to the neutral line of the system.

TERASAKI can provide this neutral line CT as an option.

For the 4-pole ACB, a measuring CT instead of the neutral line CT is already built into the neutral phase of the ACB when the ground fault protection is fitted.

### Outline dimension of CT for neutral line

AR208S, AR212S, AR216S  
AR212H, AR216H, AR316H

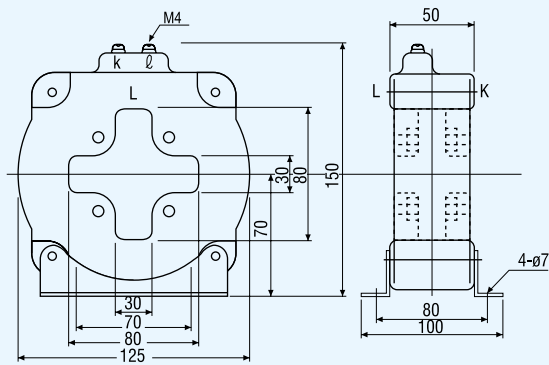

Type	CW80-40LS	
Rated Primary Current (A)	200	1250
Rated Primary Current (A)	400	1600
Rated Primary Current (A)	800	

Rated secondary current is 5A \*

AR220S, AR325S, AR332S, AR440SB, AR440S, AR650S, AR663S  
AR220H, AR320H, AR325H, AR332H, AR420H, AR440H, AR663H

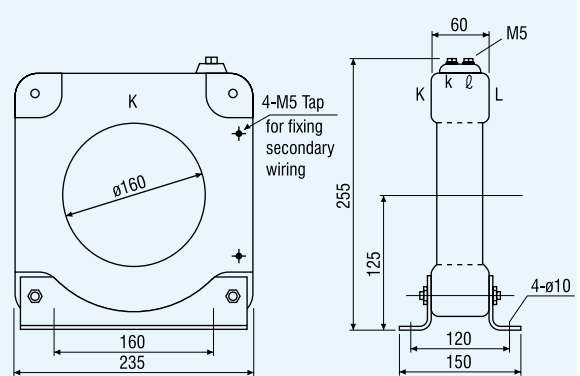

Type	EC160-40LS	
Rated Primary Current (A)	1600	4000
Rated Primary Current (A)	2000	5000
Rated Primary Current (A)	2500	6300
Rated Primary Current (A)	3200	

Rated secondary current is 5A \*

The over-current trip device of **TemPower 2** provides a ground fault protection on the line side (optional) as well as on the load side as shown above. When the ACB is used for protection of a 3-pole, 4-wire system, select the same current transformer for the neutral line shown above. Two current transformers are required for 3 pole restricted earth fault ACBs.

\* Note: Neutral CT must be mounted with face K towards the ACB upper terminals irrespective of power direction.



# Installing the TemPower 2 ACB

## SECTION

## 4

▶	<b>Operation Environments</b> .....	<b>55</b>
▶	<b>Dimensions</b> .....	<b>56-69</b>
▶	<b>Connections</b> .....	<b>70-75</b>
▶	<b>Circuit Diagrams</b> .....	<b>76-81</b>





## Operation Environments

### Standard environment

The standard environment for ACBs is follows:

<b>Ambient Temperature</b>	De-rating applies outwith the temperature range -5°C to +50°C the average temperature for 24 hours must not exceed 35°C.
<b>Relative humidity</b>	Below 85%
<b>Altitude</b>	Below 2000m
<b>Atmosphere</b>	Excessive water vapor, smoke, dust or corrosive gases must not exist. Sudden change in temperature, condensation or icing must not occur.
<b>Vibration</b>	The <b>TemPower 2</b> ACB is designed to withstand electromagnetic and mechanical vibrations in accordance with IEC 68-2-6. (2-13.2 Hz with amplitude of +/- 1mm; 13.2 to 100 Hz with an acceleration of 0.7g).
<b>Storage and Operation Temperature</b>	Min. permissible temperature -20°C
	Max. permissible temperature 60°C
	No condensation
<b>Shock</b>	Shock withstand = 15g (AR208S, AR212S, AR216S, AR220S, AR212H, AR216H, AR220H, AR325S, AR332S, AR316H, AR320H, AR325H, AR332H. Contact us for shock withstand ratings of other models).

### Special environment

#### Tropicalisation (Fungus and moisture treatment)

Specify this treatment when the ACB is used under high temperature and high humidity conditions.

<b>Conditions</b>	Max. permissible ambient temperature 60°C
	Max. permissible humidity 95% rel.
	No condensation

#### Cold climate treatment

Specify this treatment when the ACB is used in cold areas.

<b>Conditions</b>	Min. permissible storage temperature -40°C (max 60°C)
	Min. permissible operating temperature -25°C (max 40°C)
	No condensation

#### Anti-corrosion treatment

Specify this treatment when the ACB is used in a corrosive atmosphere.

Contact Terasaki for details.



# Dimensions

Type: AR208S, AR212S, AR216S, AR220S  
AR212H, AR216H, AR220H Draw-out type

Ⓟ: ACB Front cover center line

## Terminal size

Type	(t <sub>1</sub> )	(t <sub>2</sub> )	(t <sub>3</sub> )	W
AR208S	10	10	15	17.5
AR212S	10	10	15	17.5
AR216S	20	15	25	22.5
AR220S	20	15	25	—
AR212H	20	15	—	—
AR216H	20	15	—	—
AR220H	20	15	—	—

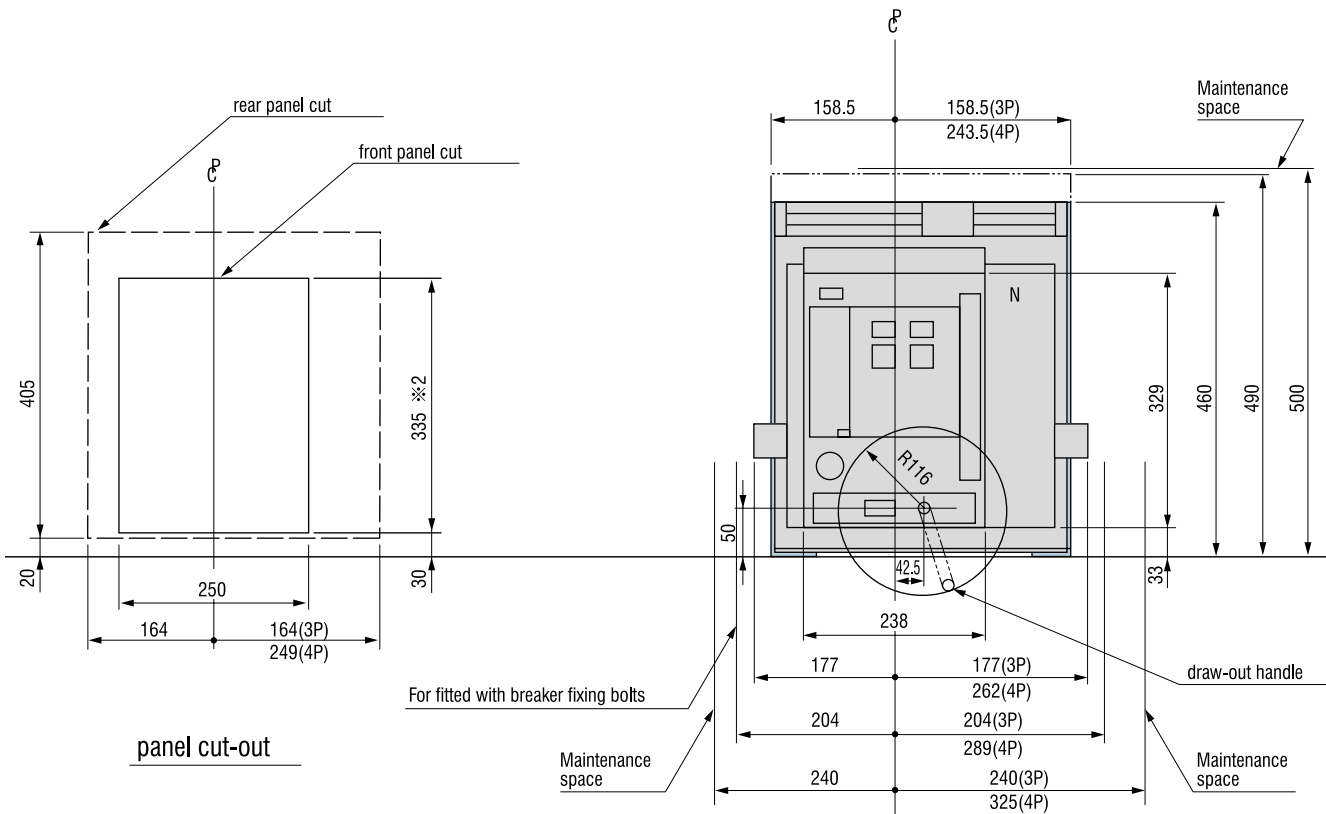

※1: Conductors including connecting bolts should be separated min. 7mm from Draw-out arm.

※2: Panel cut should be 339 mm not 335 mm when the door flange is used.

- N represents the neutral pole of 4-pole ACB  
The neutral pole is positioned to the right as standard when viewed from the front of the ACB. However, the neutral pole can be customized so that it is positioned to the left.
- For High fault series vertical terminal is standard and horizontal terminal is optional, and front connection is not available.
- The vertical terminal for the main circuit with its length extended by 70 mm from the standard is specially available on request.
- For the outline drawing for the version with earth leakage tripping, contact us.

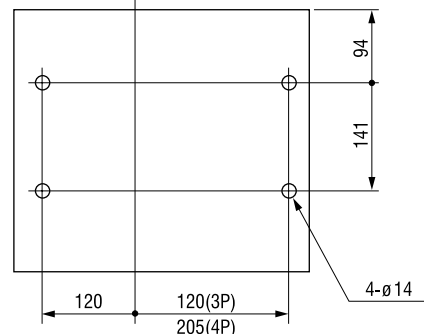

Mounting holes





## Dimensions

Type: AR208S, AR212S, AR216S, AR220S  
AR212H, AR216H, AR220H Fixed type

$\mathcal{P}$  : ACB Front cover centre line

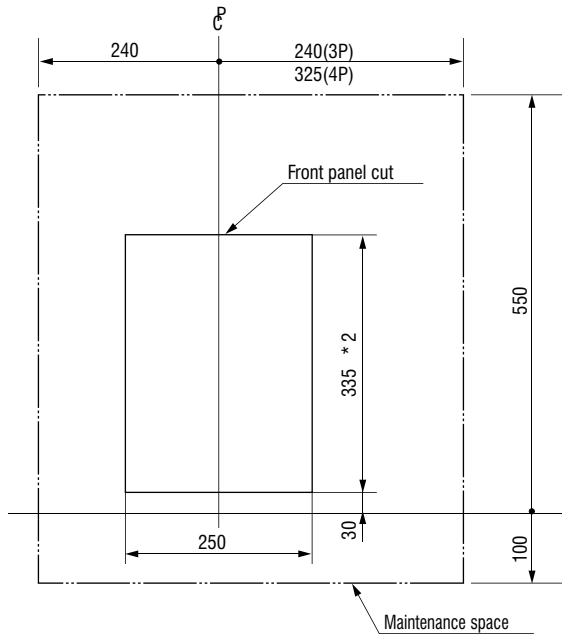
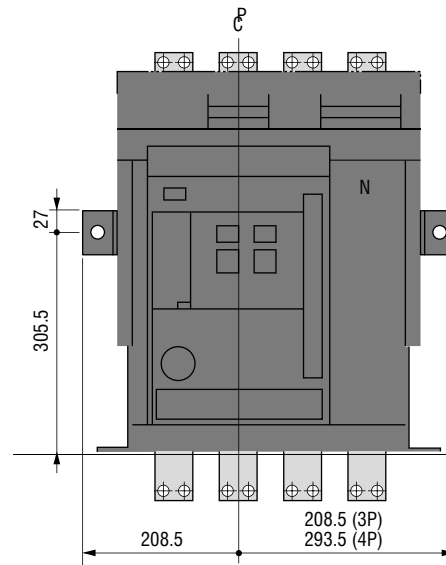

Panel cutout

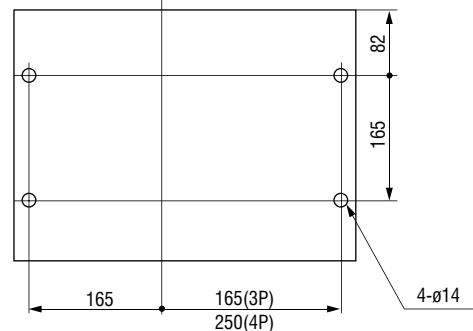
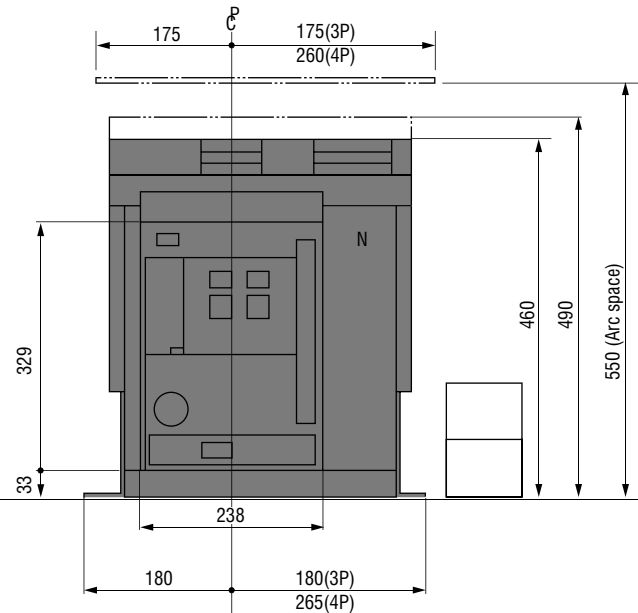

Mounting holes

### Terminal size

Type	t <sub>1</sub>	t <sub>2</sub>	t <sub>3</sub>	W
AR208S	10	10	15	17.5
AR212S	10	10	15	17.5
AR216S	20	15	25	22.5
AR220S	20	15	25	—
AR212H	20	15	—	—
AR216H	20	15	—	—
AR220H	20	15	—	—

\* 2: Panel cut should be 339 mm not 335 mm when the door flange is used.

- N represents the neutral pole of 4-pole ACB  
The neutral pole is positioned to the right as standard when viewed from the front of the ACB. However, the neutral pole can be customised so that it is positioned to the left.
- For Type AR-H high fault series, vertical terminals are standard, horizontal terminals are optional and front connections are not available.
- For the outline drawing for the version with earth leakage tripping, contact us.

4



# Dimensions

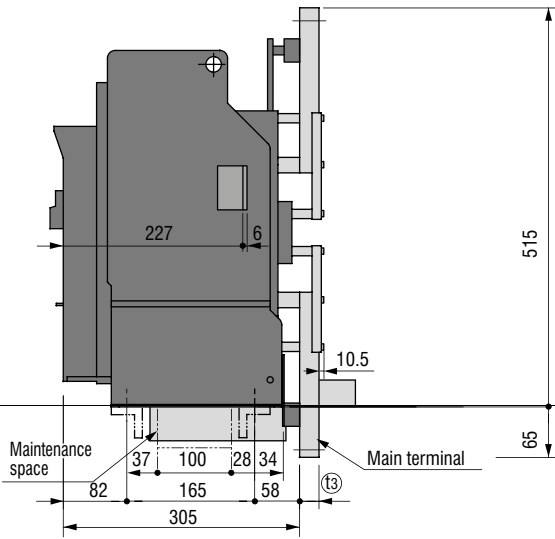

## Front connections

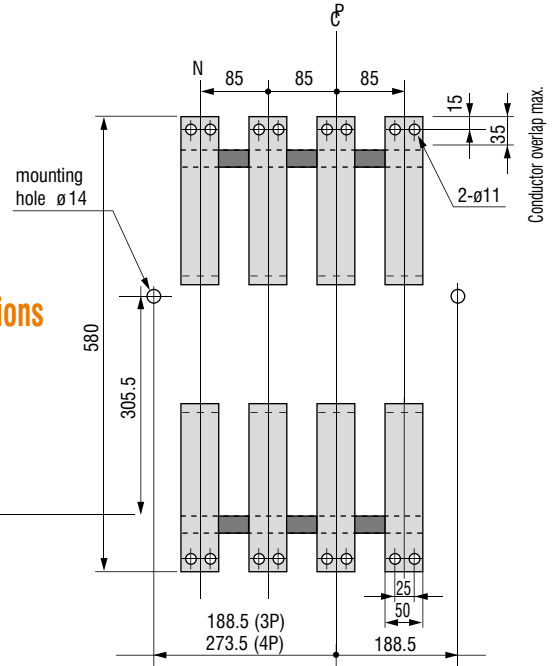

AR220S  
AR212H  
AR216H  
AR220H

AR208S  
AR212S  
AR216S

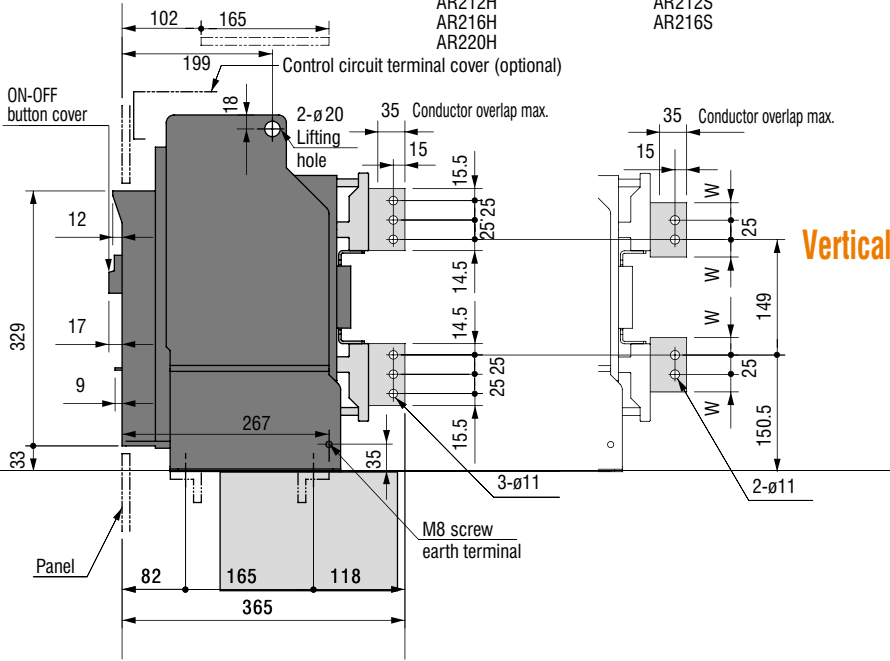

## Vertical terminals

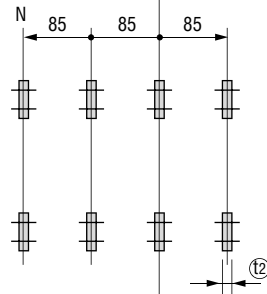

## Horizontal terminals

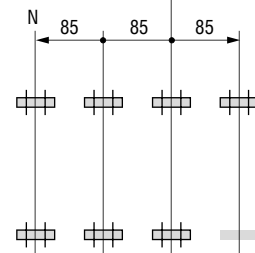



# Dimensions

Type: AR325S, AR332S,  
AR316H, AR320H, AR325H, AR332H Draw-out type

$\mathcal{P}$  : ACB Front cover centre line

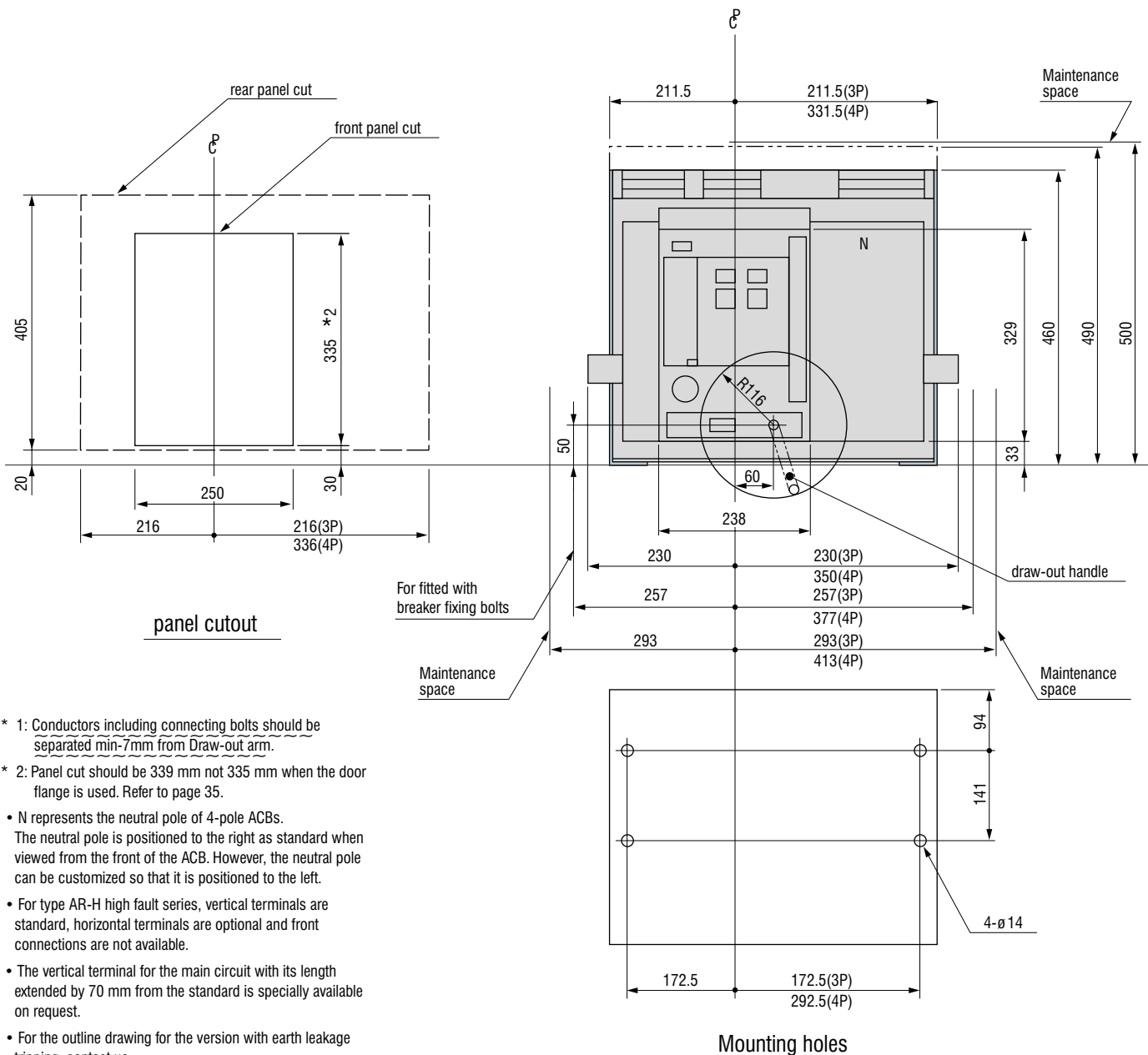

- \* 1: Conductors including connecting bolts should be separated min-7mm from Draw-out arm.
- \* 2: Panel cut should be 339 mm not 335 mm when the door flange is used. Refer to page 35.
- N represents the neutral pole of 4-pole ACBs. The neutral pole is positioned to the right as standard when viewed from the front of the ACB. However, the neutral pole can be customized so that it is positioned to the left.
- For type AR-H high fault series, vertical terminals are standard, horizontal terminals are optional and front connections are not available.
- The vertical terminal for the main circuit with its length extended by 70 mm from the standard is specially available on request.
- For the outline drawing for the version with earth leakage tripping, contact us.





# Dimensions

Type: AR325S, AR332S,  
AR316H, AR320H, AR325H, AR332H Fixed type

$\mathcal{C}$  : ACB Front cover centre line

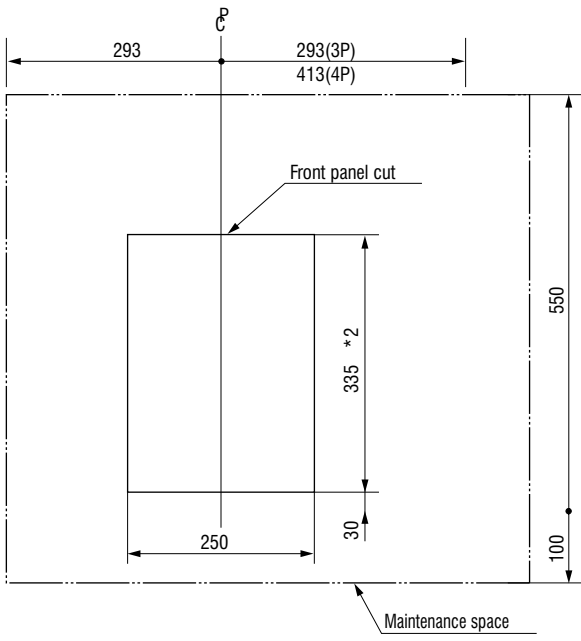
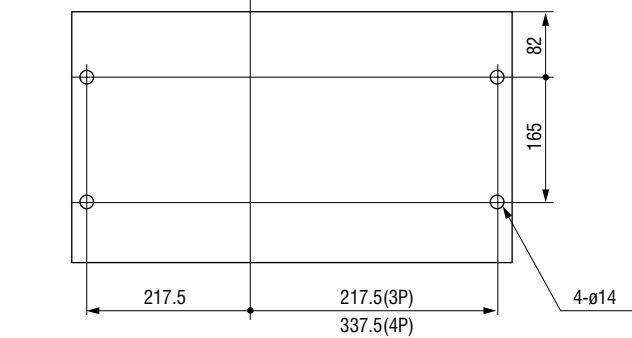
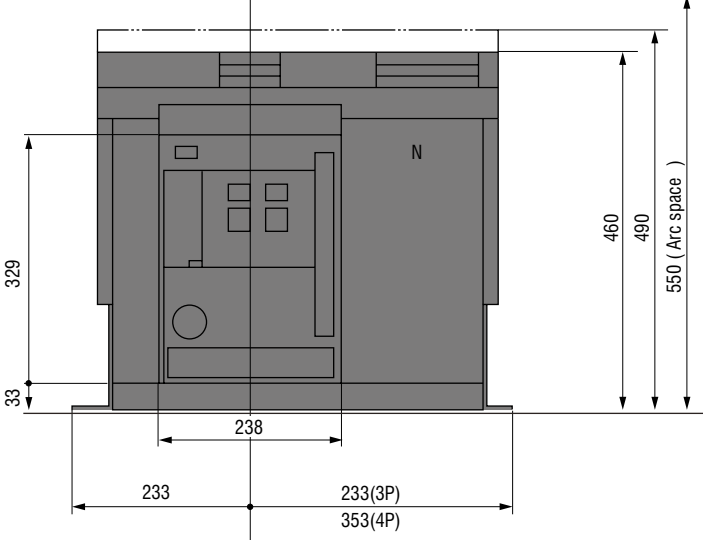
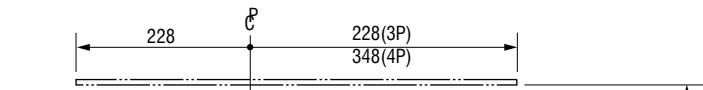
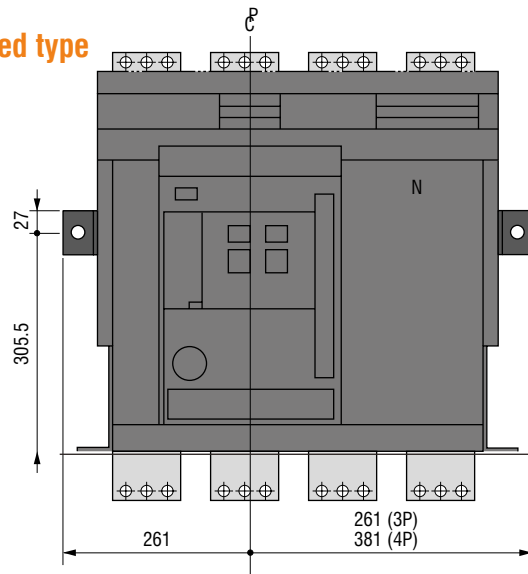

Panel cutout

Mounting holes

\* 2: Panel cut should be 339 mm not 335 mm when the door flange is used. Refer to page 35.

- N represents the neutral pole of 4-pole ACBs. The neutral pole is positioned to the right as standard when viewed from the front of the ACB. However, the neutral pole can be customized so that it is positioned to the left.
- For type AR-H high fault series, vertical terminals are standard, horizontal terminals are optional and front connections are not available.
- For the outline drawing for the version with earth leakage tripping, contact us.



# Dimensions

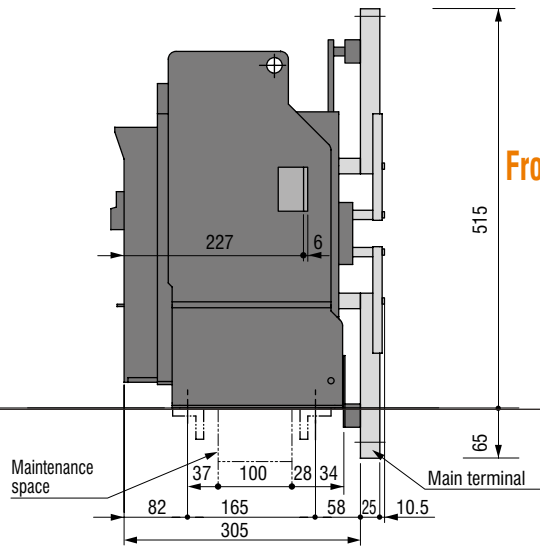

Front connections

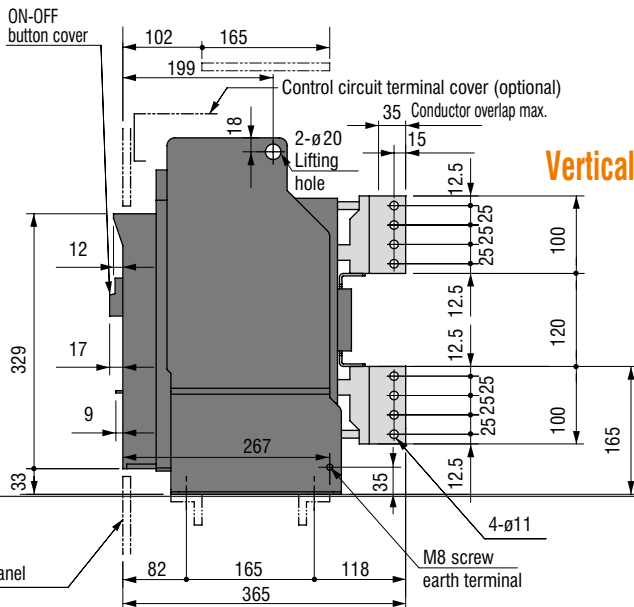
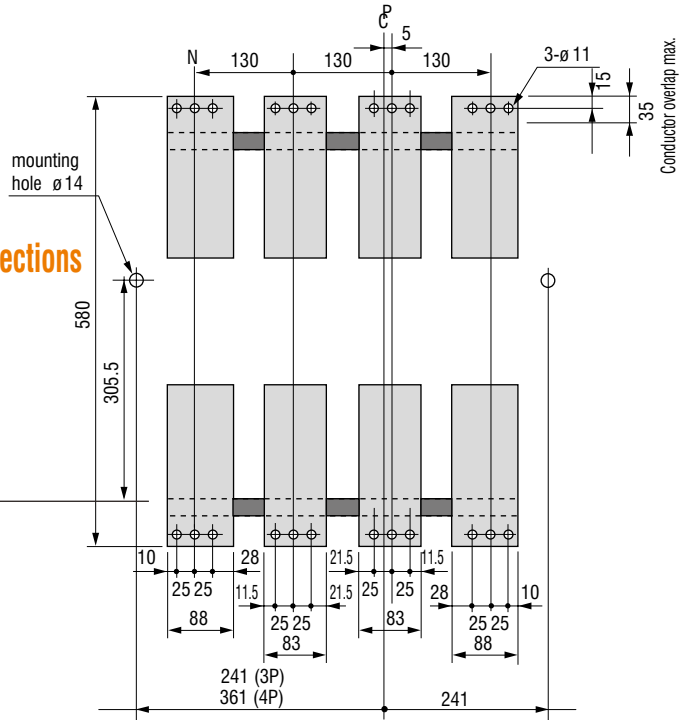

Vertical terminals

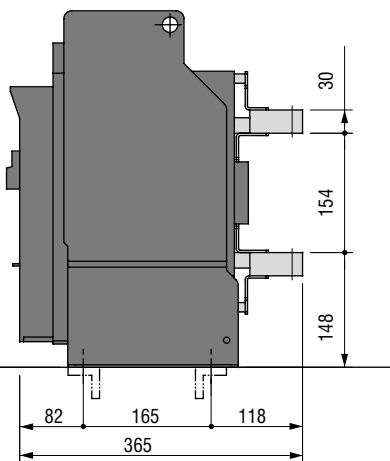
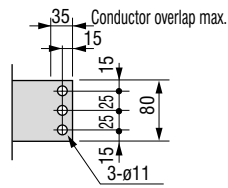
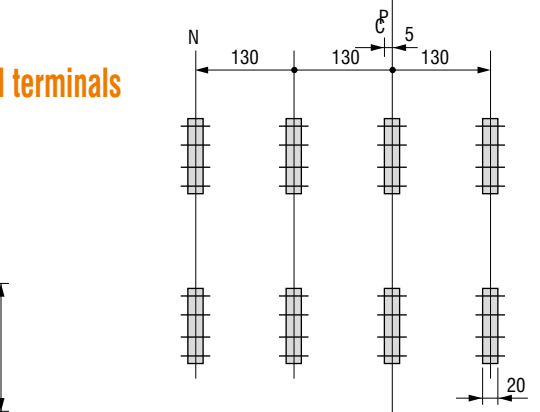

Horizontal terminals

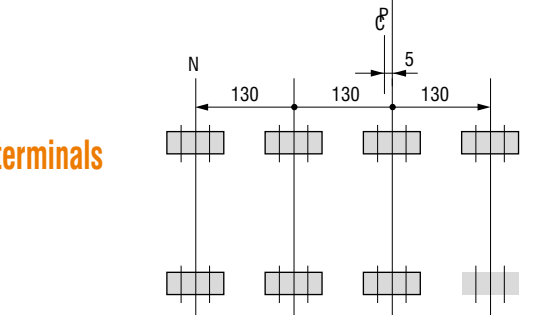



## Type: AR440SB Draw-out type

$\mathcal{C}$  : ACB Front cover centre line

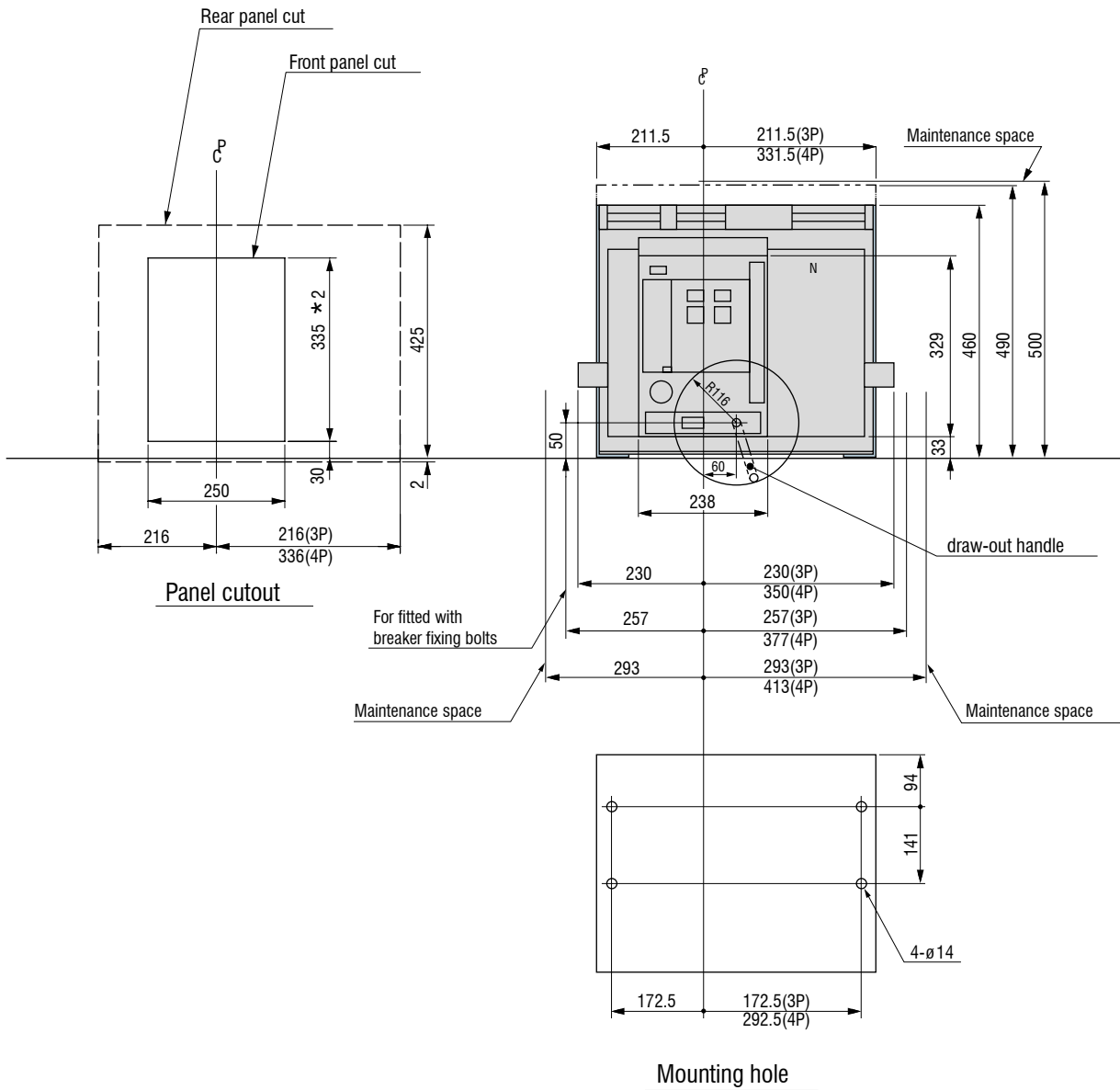

\*2: Panel cut should be 339 mm not 335 mm when the door flange is used. Refer to page 35.

• N represents the neutral pole of 4-pole ACBs.



# Dimensions

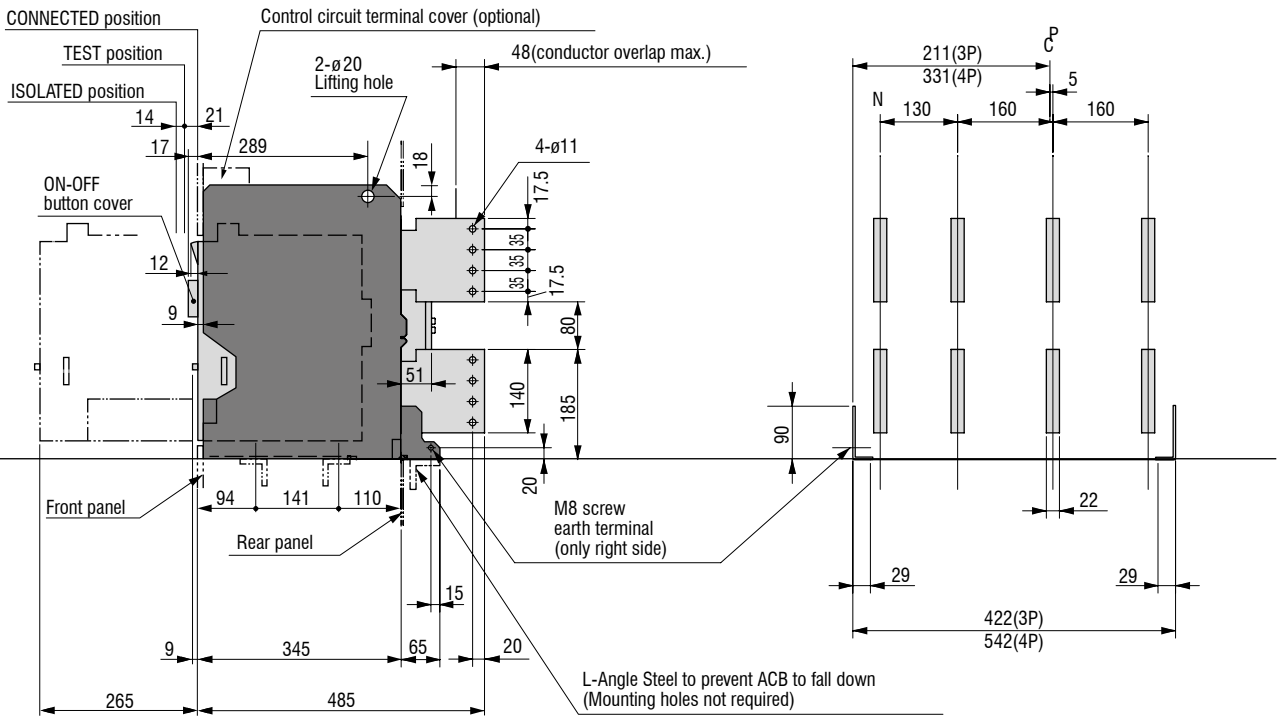

**Types: AR440S, AR420H (3 poles only), AR440H (3 poles only)**  
**Draw-out type**

**C** : ACB Front cover centre line

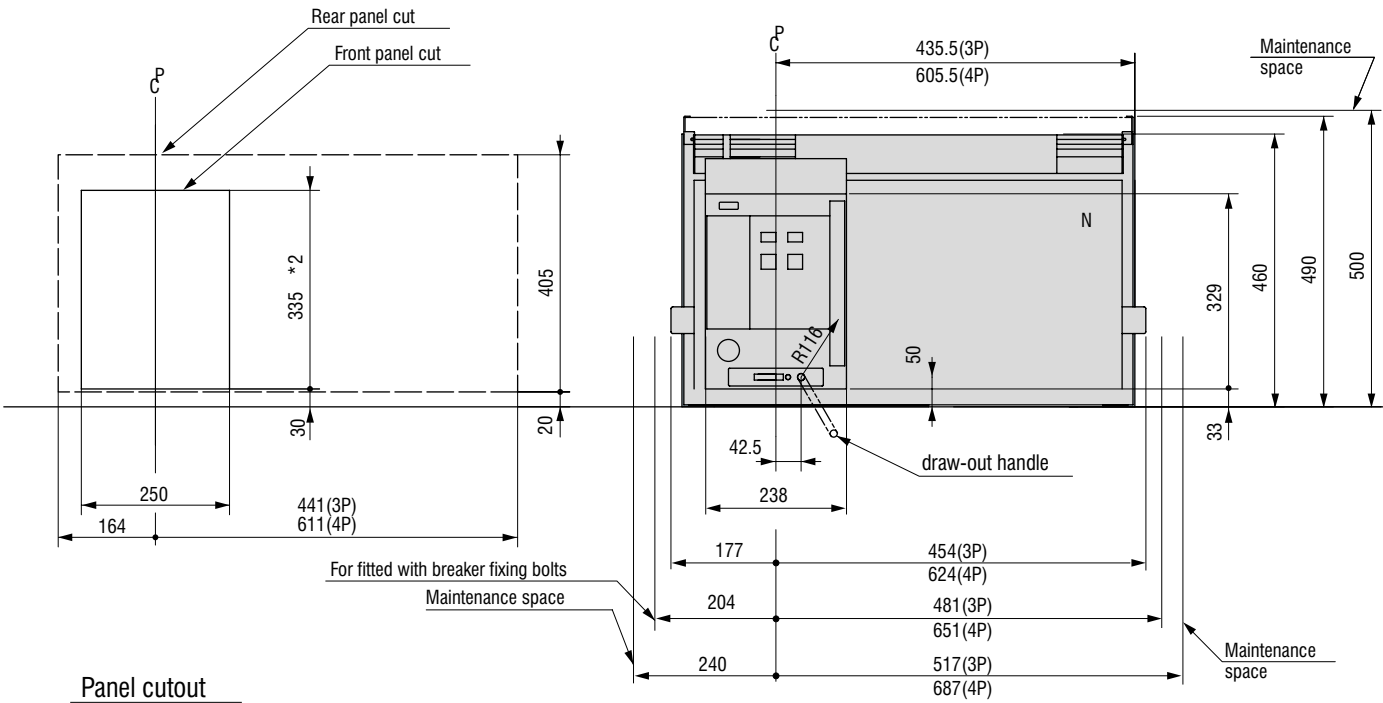

4

- \* 1: Conductors including connecting bolts should be separated min-7mm from Draw-out arm.
- \* 2: Panel cut should be 339 mm not 335 mm when the door flange is used. Refer to page 35.
- N represents the neutral pole of 4-pole ACBs.
- AR420H and AR440H are 3 poles only.



# Dimensions

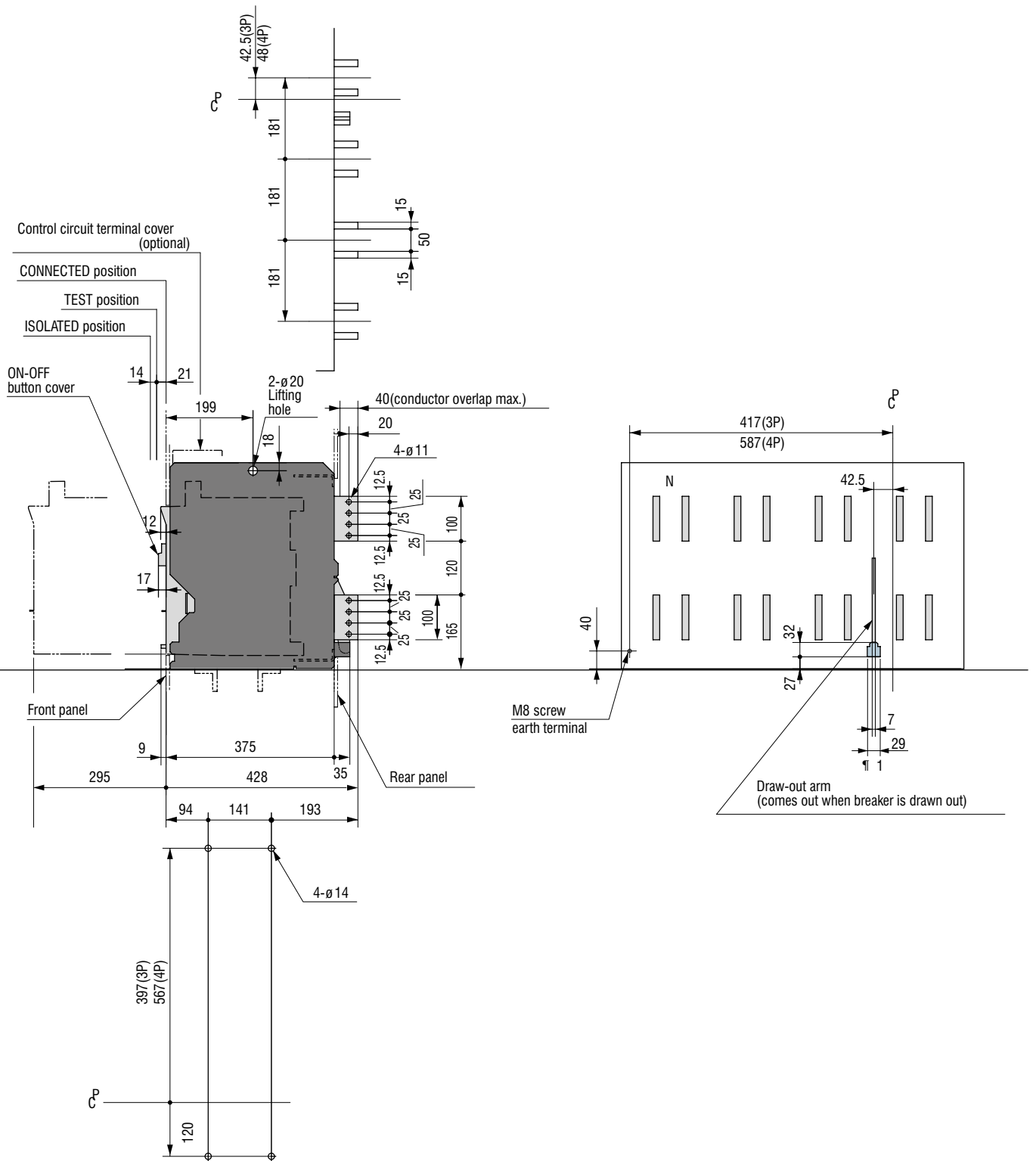

4



# Dimensions

Type: AR650S, AR663S,  
AR663H, Draw-out type

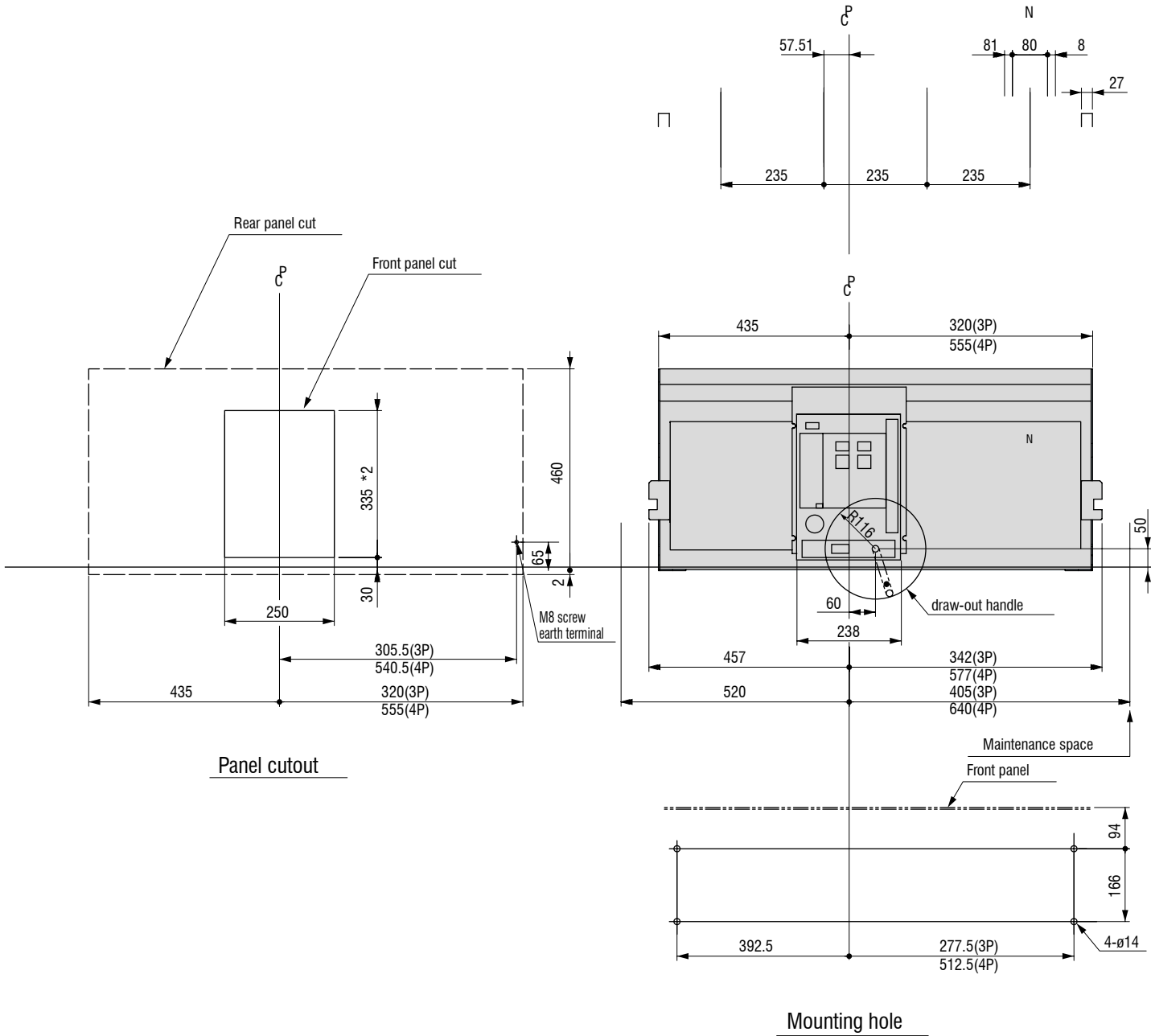

\*2 : Panel cut should be 339 mm not 335 mm when the door flange is used. Refer to page 35.

• N represents the neutral pole of 4-pole ACBs.



# Dimensions

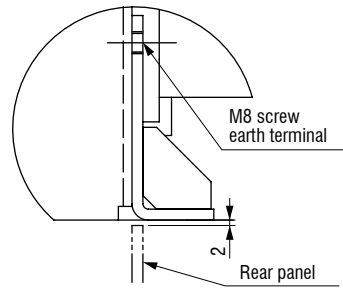
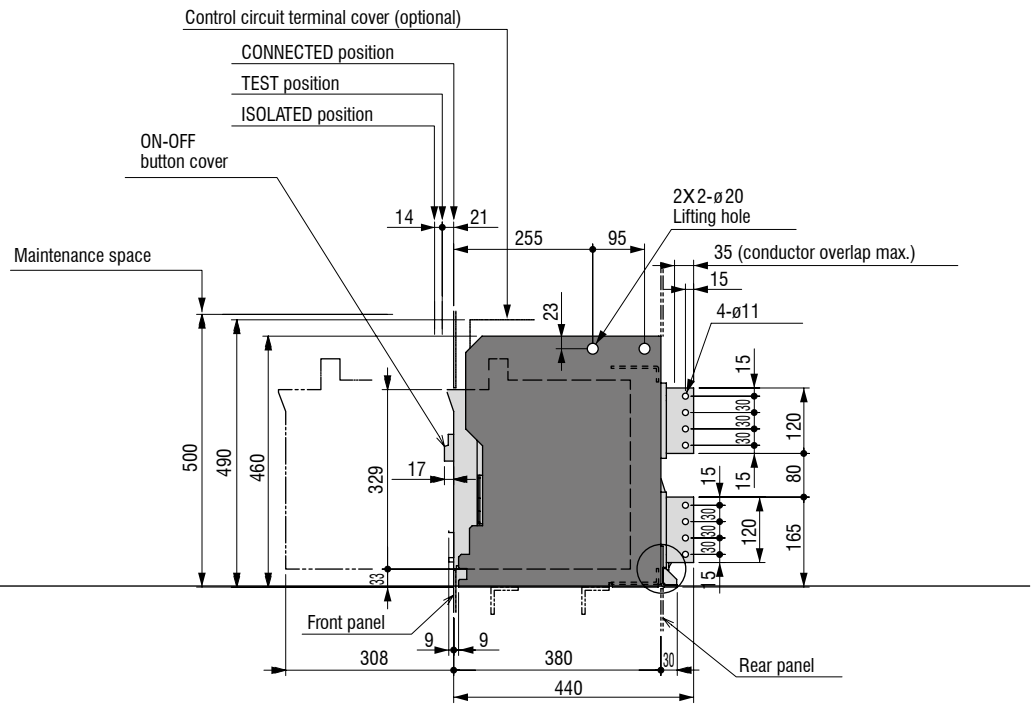

Details



Connect conductors to the main circuit terminals in the conductor connection.

Insulation distance of conductor connection area and earth metal is more than 12.5mm. (\*Not available on H-Type).

## Types: AR208S, AR212S, AR216S, AR220S, AR212H, AR216H, AR220H

(Front connections are not available on H Type ACBs)

### Vertical terminals 3P

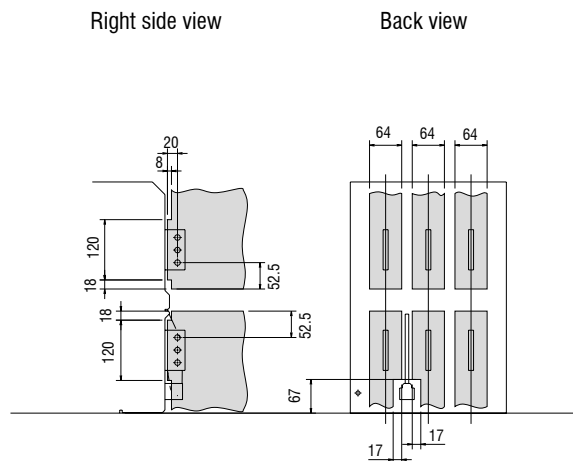

### Vertical terminals 4P

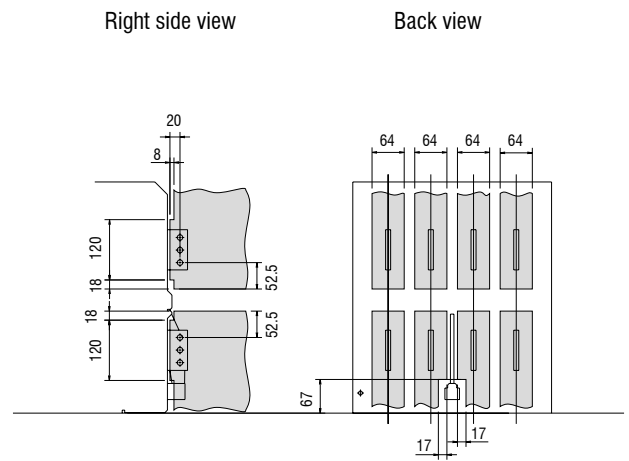

### Horizontal terminals 3P

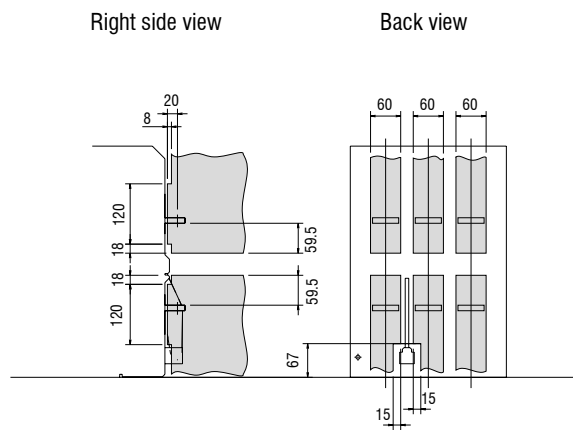

### Horizontal terminals 4P

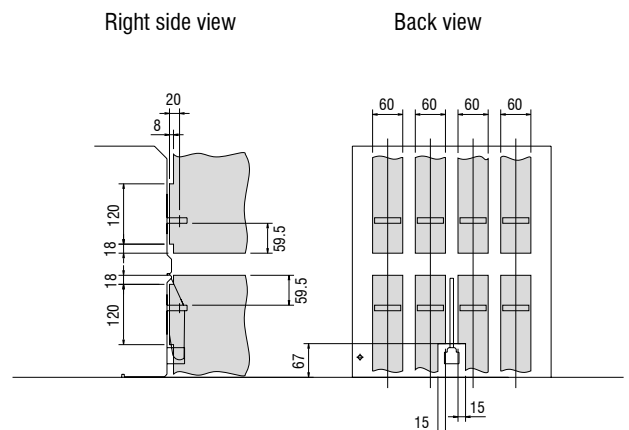

### Front connections 3P\*

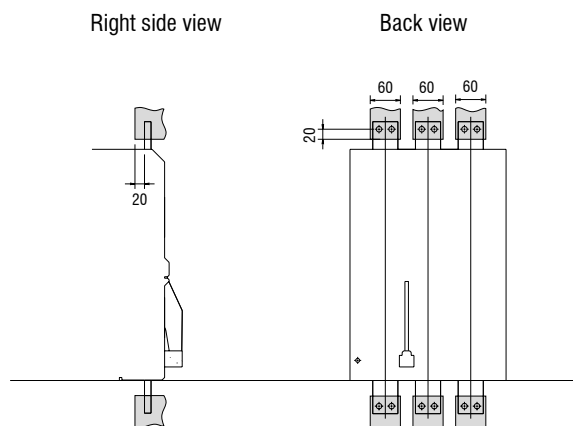

### Front connections 4P\*

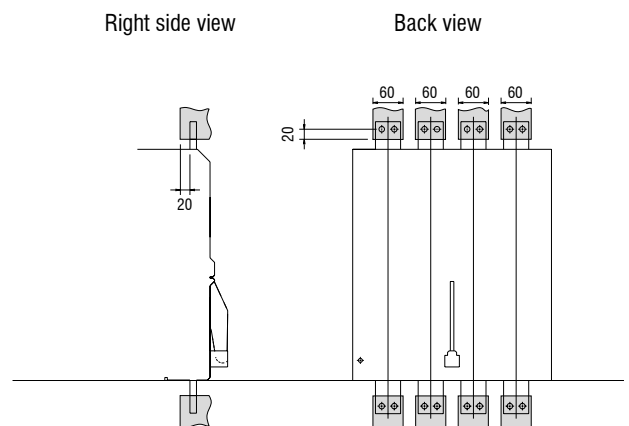

4



Types: AR325S, AR332S, AR316H, AR320H, AR325H, AR332H

Vertical terminals 3P

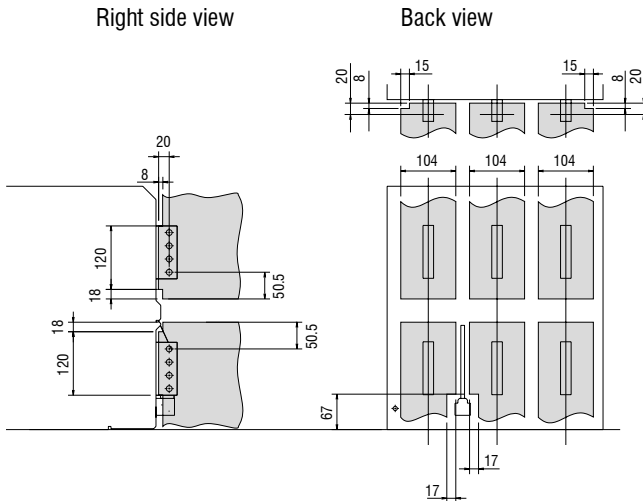

Vertical terminals 4P

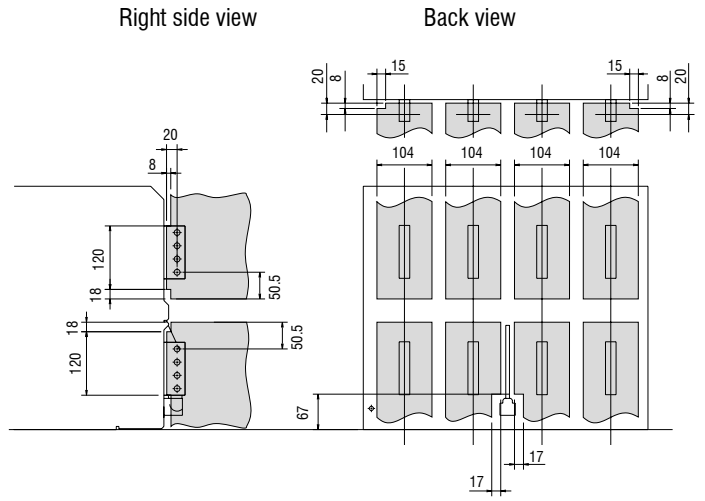

Horizontal terminals 3P

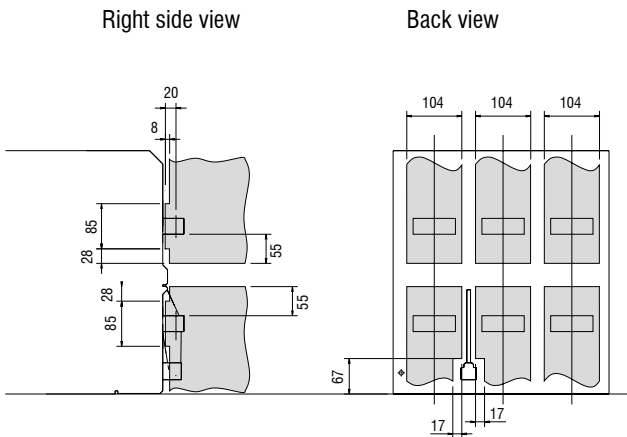

Horizontal terminals 4P

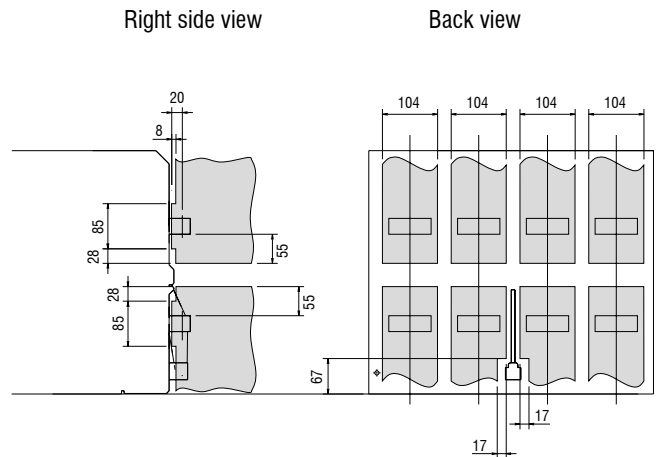

Front connections 3P\*

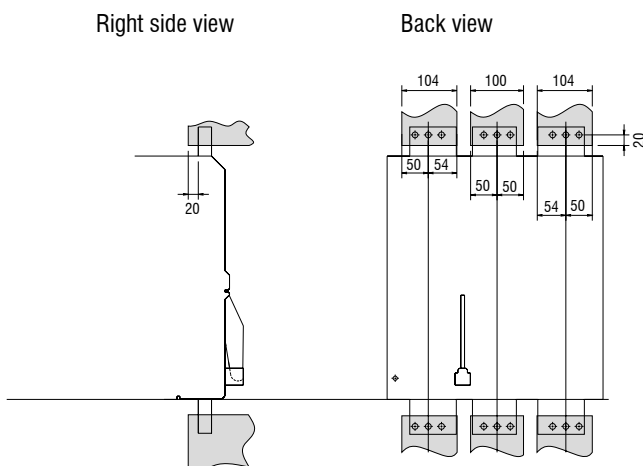

Front connections 4P\*

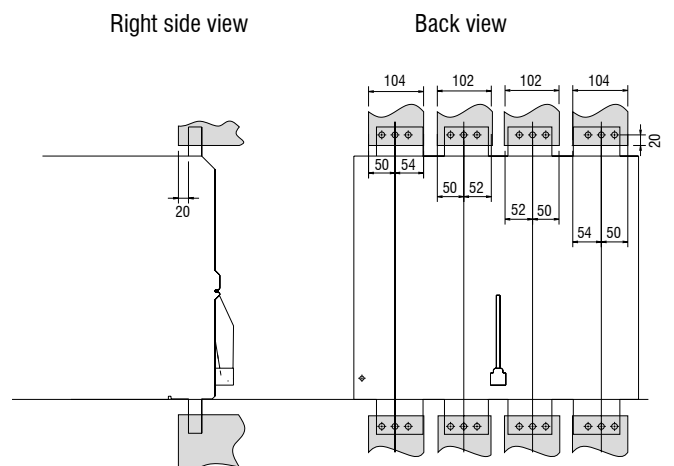



Types: AR440S, AR420H, AR440H

■ Vertical terminals 3P

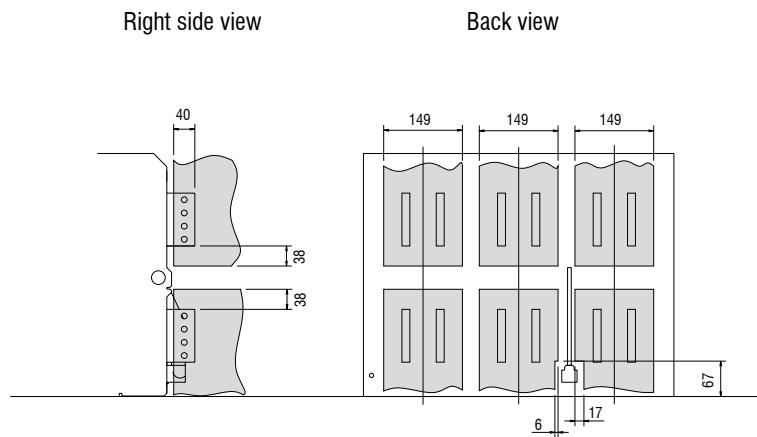

4

■ Vertical terminals 4P

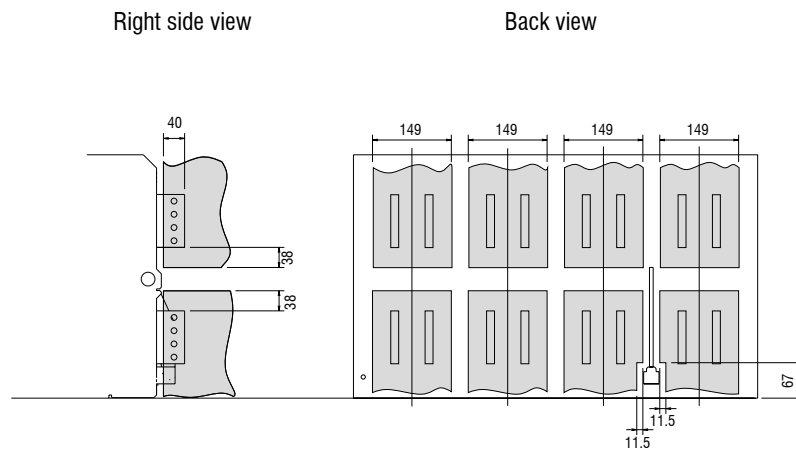



Type: AR440SB

■ Vertical terminals 3P

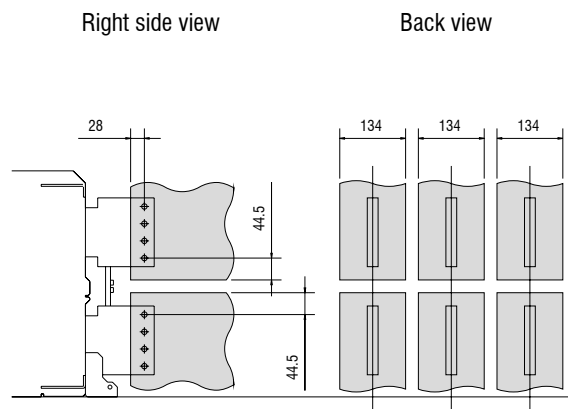

■ Vertical terminals 4P

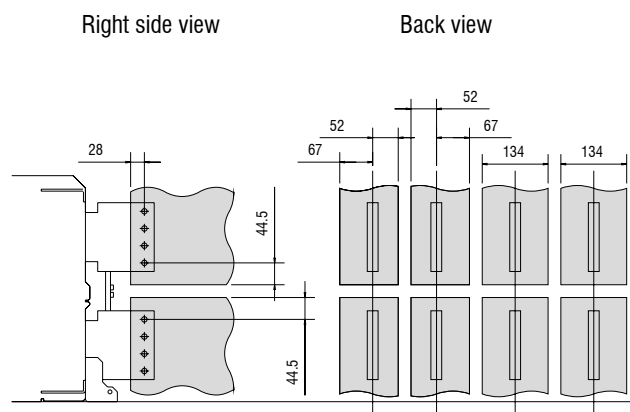



Types: AR650S, AR663S, AR663H

■ Vertical terminals 3P

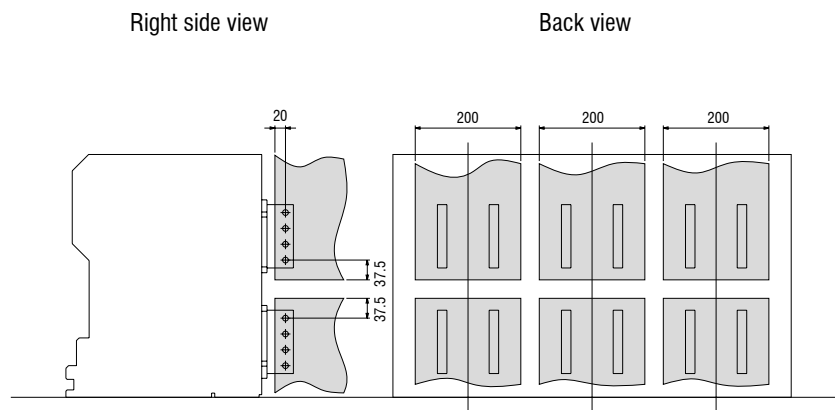

4

■ Vertical terminals 4P

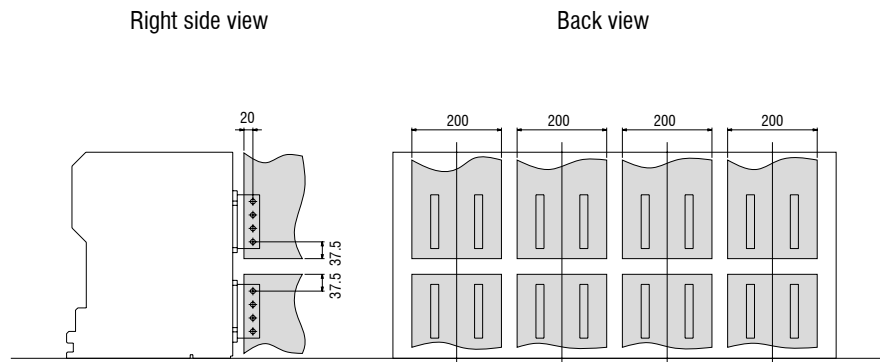

When two busbars are connected to a terminal stud of the ACB, sandwich the terminal stud between the two busbars to utilise both surfaces of the terminal. A spring and plain washer must be used in conjunction with the busbar bolt and nut as below.

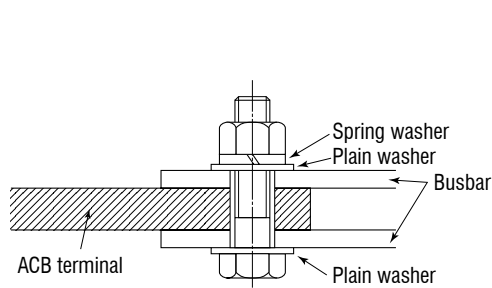

In case of 1 terminal per pole

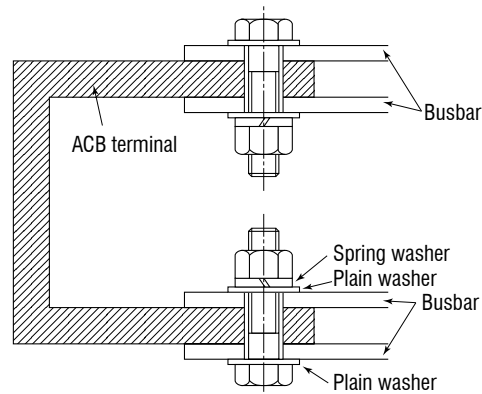

In case of 2 terminals per pole

### Recommendation for Busbars connection

The busbars to the ACB should be firmly supported near the ACB terminal. Fault currents flow through the busbars developing a large electromagnetic force between the busbars. The support must be strong enough to withstand such forces and ensure enough insulating distance. The ACB should not be relied on as a single support.

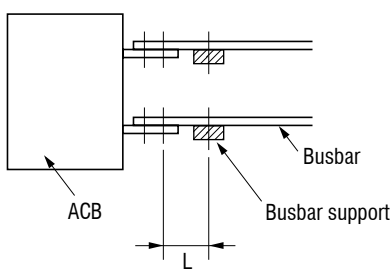
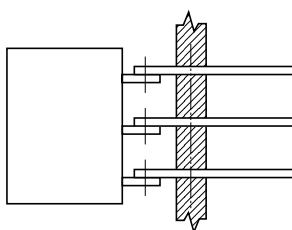
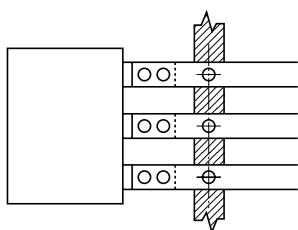

Horizontal terminals

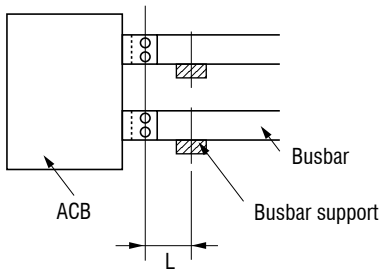

Vertical terminals

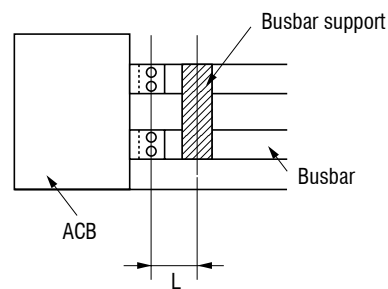

Vertical terminals

Short-circuit current (kA)		30	50	65	80	100	120	135
Distance L (mm)	AR2	300	250	150	150	---	---	---
	AR3	350	300	250	150	150	---	---
	AR440SB	350	300	250	150	100	---	---
	AR440S, AR420H, AR440H	350	300	250	150	150	100	---
	AR6	350	300	250	150	150	150	150



# Circuit Diagram (with AGR-11B Protection Relay)

Main circuit

CT for neutral line

Operation

※3 Motor charging/ Operation circuit

Continuously-rated shunt trip

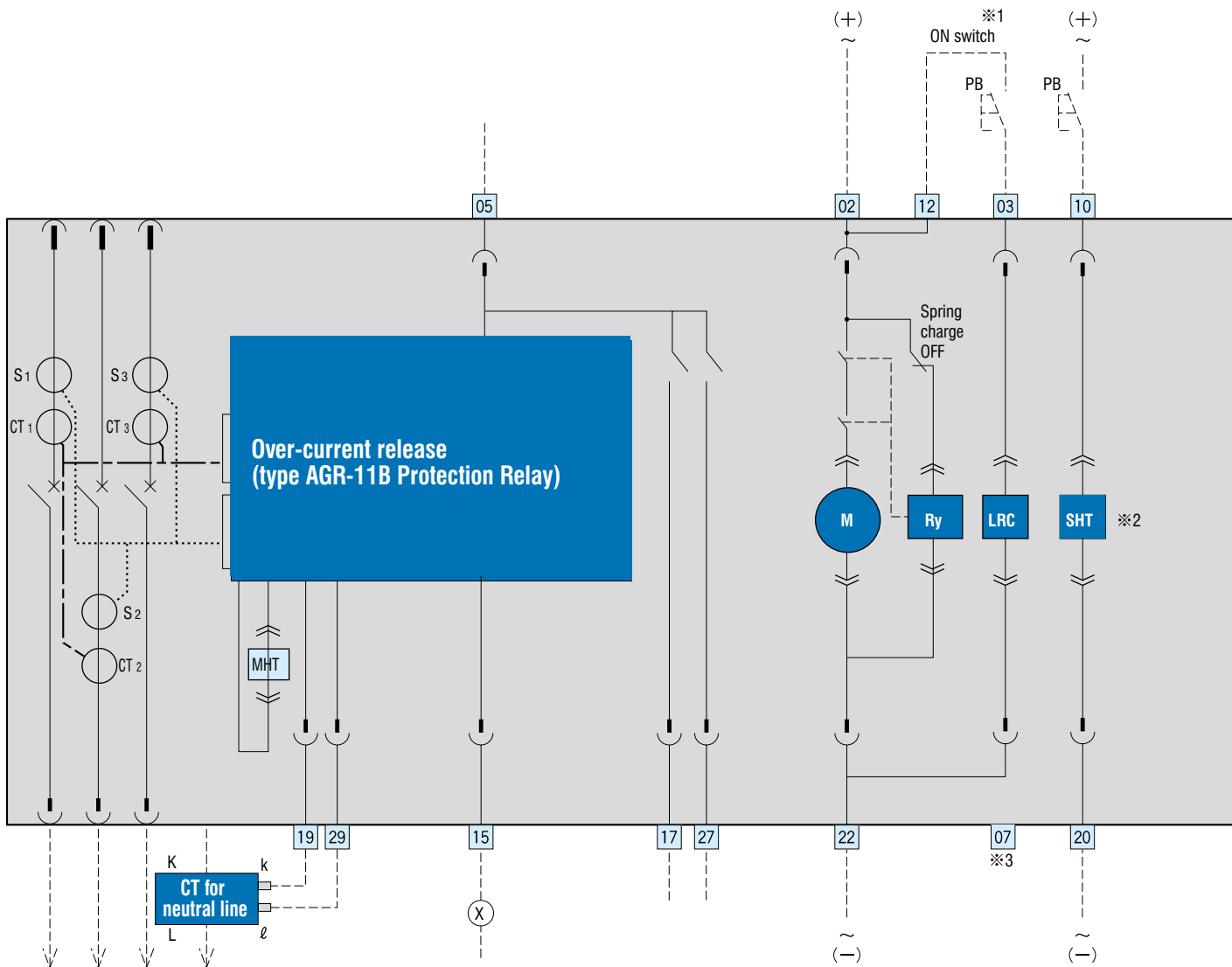

## Terminal description

Check protection relay voltage before connecting.

- 02 22 Control power supply AC100 - 240V, DC100 - 250V, DC24V, DC48V
- 12 Operation switch, common
- 03 ON switch
- 05 Operation indication terminal, common
- 15 Protection relay trip indication or single-contact trip indication (AL/GL 40ms signal, AS/GS latching)
- 17 Trip indication (not ready indication)
- 27 Spring charge indicator
- 10 20 Continuously-rated shunt trip
- 19 Separate CT for neutral line (k)
- 29 Separate CT for neutral line (ℓ)
- 08, 18, 28 UVT power supply
- 09 UVT power supply common

• Do not exceed specified voltages

### UVT power supply

Term. No.	AC 100V unit	AC 200V unit	AC 400V unit	AC 450V unit
08 — 09	100V	200V	380V	450V
18 — 09	110V	220V	415V	480V
28 — 09	120V	240V	440V	400V

Term. No.	DC 24V unit	DC 48V unit	DC 100V unit	DC 110V unit
08 — 09	24V	48V	100V	110V

## Symbols for accessories

- CT1 - CT3 : Power CTs
- S1 - S3 : Current sensors
- M : Charging motor
- LRC : Latch release coil
- MHT : Magnetic Hold Trigger
- ⊖ Isolating terminal connector (for draw-out type)
- ⊖ Manual connector
- User wiring
- ⊖ Relay or indicator lamp

- ※1: Do not connect "b" contact of auxiliary switch to ON switch in series, otherwise, pumping may occur.
  - ※2: See page 30 for the circuit diagram of the continuously-rated shunt trip device with capacitor trip device.
  - ※3: For motor split circuit, terminals 02, 22 and 03, 07 are used for charging and closing operation respectively. (Please specify when ordering)
  - ※4: Only one of terminals 08, 18, 28 must be used as this is a single phase UVT.
  - ※5: Do not use these terminals for other circuits when both instantaneously rated shunt trip and UVT are fitted. These terminals are used by Terasaki as the anti-burnout SW for the instantaneously rated shunt trip.
- Note: In case of a UVT and a Shunt fitted together or Double opening or closing coil, use an aux. switch to prevent burnout. Contact TERASAKI for wiring.



# Circuit Diagram (with AGR-11B Protection Relay)

## Undervoltage trip

## Position switches

## Auxiliary switches

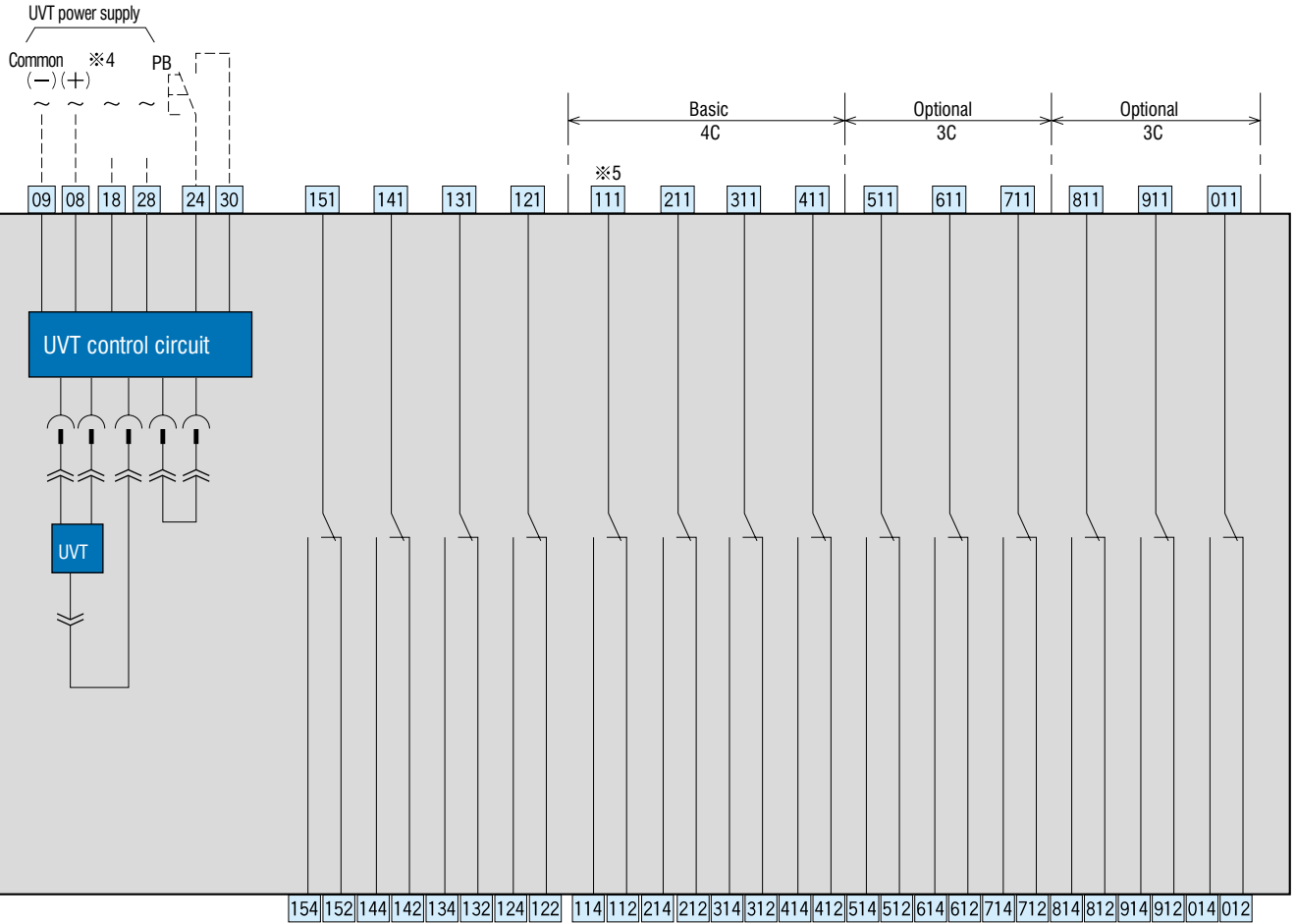

### Designation of terminals for auxiliary and position switches

- \* 1: Common
  - 2: b-contact
  - 4: a-contact
- 1: Auxiliary switch
  - 2: Position switch (for CONNECTED)
  - 3: Position switch (for TEST)
  - 4: Position switch (for ISOLATED)
  - 5: Position switch (for INSERT)
- (1 - 0: Switch numbers  
A, B, C: Auxiliary switches for microload)

CONNECTED position : 121-124 ON  
121-122 OFF

TEST position : 131-134 ON  
131-132 OFF

ISOLATED position : 141-144 ON  
141-142 OFF

INSERT position : 151-154 ON  
151-152 OFF

For operation sequence of position switches, see page 27.

### Position switches

Top	151	141	131	121
Middle	154	144	134	124
Bottom	152	142	132	122

Top	131	121
Middle	134	124
Bottom	132	122

### Operation/control circuits

01	02	03	04	05	06	07	08	09	10
11	12	13	14	15	16	17	18	19	20
21	22	23	24	25	26	27	28	29	30

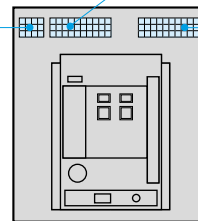

### Auxiliary switches

(4c + optional 6c arrangement)

111	211	311	411	511	611	711	811	911	011
114	214	314	414	514	614	714	814	914	014
112	212	312	412	512	612	712	812	912	012

(4c arrangement)

111	211	311	411
114	214	314	414
112	212	312	412



# Circuit Diagram (with AGR-21B Protection Relay)

Main circuit

CT for neutral line

Control power

Operation

※3 Motor charging/ Operation circuit

Continuously-rated shunt trip

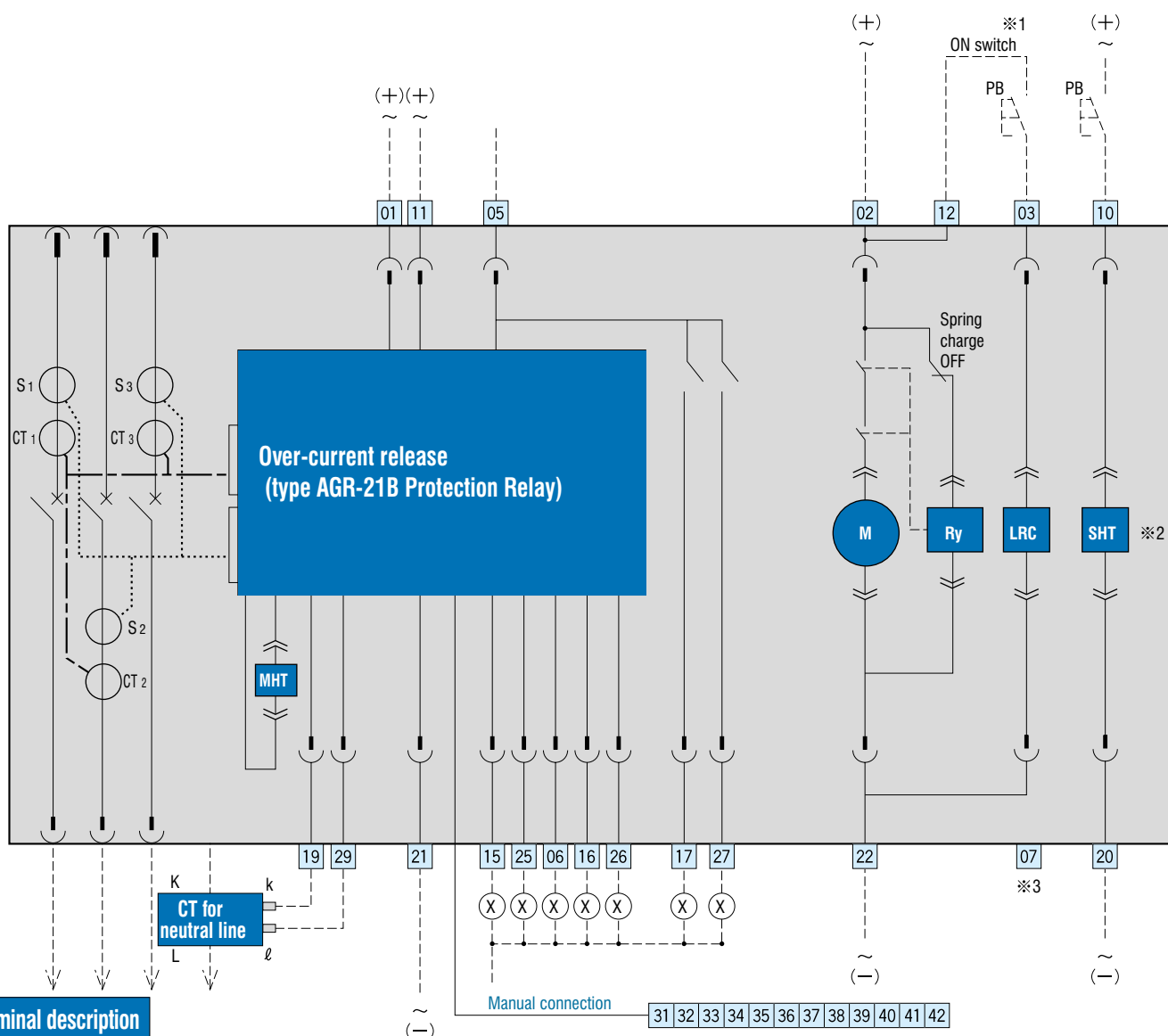

## Terminal description

Check protection relay voltage before connecting.

- 01 21 Control power supply AC200 - 240V, DC200 - 250V, DC48V
- 01 11 Control power supply AC100 - 120V
- 11 21 Control power supply DC100 - 125V, DC24V
- 02 22 Control power supply AC100 - 240V, DC100 - 250V, DC24V, DC48V
- 12 Operation switch, common
- 03 ON switch
- 05 Operation indication terminal, common
- 15 LT trip indication
- 25 ST, INST trip indication
- 06 PTA indication
- 16 GF trip indication
- 26 System alarm indication
- 17 REF, NS or trip indication
- 27 Spring charge indication
- 10 20 Continuously-rated shunt trip
- 19 Separate CT for neutral line (k)

- 29 Separate CT for neutral line (ℓ)
- 08, 18, 28 UVT power supply
- 09 UVT power supply common
- 35 Separate CT for REF (k)
- 36 Separate CT for REF (ℓ)
- 41 Communication line (-)
- 42 Communication line (+)
- 32 Communication line (common)

### • Do not exceed specified voltages

UVT power supply

Term. No.	AC 100V unit	AC 200V unit	AC 400V unit	AC 450V unit
08 - 09	100V	200V	380V	450V
18 - 09	110V	220V	415V	480V
28 - 09	120V	240V	440V	400V

Term. No.	DC 24V unit	DC 48V unit	DC 100V unit	DC 110V unit
08 - 09	24V	48V	100V	110V

## Symbols for accessories

- CT1 - CT3 : Power CTs
- S1 - S3 : Current sensors
- M : Charging motor
- LRC : Latch release coil
- MHT : Magnetic Hold Trigger
- ↔ Isolating terminal connector (for draw-out type)
- ↔ Manual connector
- User wiring
- (X)- Relay or indicator lamp

- ※1: Do not connect "b" contact of auxiliary switch to ON switch in series, otherwise, pumping may occur.
  - ※2: See page 30 for the circuit diagram of the continuously-rated shunt trip device with capacitor trip device.
  - ※3: For motor split circuit, terminals 02, 22 and 03, 07 are used for charging and closing operation respectively. (Please specify when ordering)
  - ※4: Only one of terminals 08, 18, 28 must be used as this is a single phase UVT.
  - ※5: Do not use these terminals for other circuits when both instantaneously rated shunt trip and UVT are fitted. These terminals are used by Terasaki as the anti-burnout SW for the instantaneously rated shunt trip.
- Note: In case of a UVT and a Shunt fitted together or Double opening or closing coil, use an aux. switch to prevent burnout. Contact TERASAKI for wiring.



# Circuit Diagram (with AGR-21B Protection Relay)

## Undervoltage trip

## Position switches

## Auxiliary switches

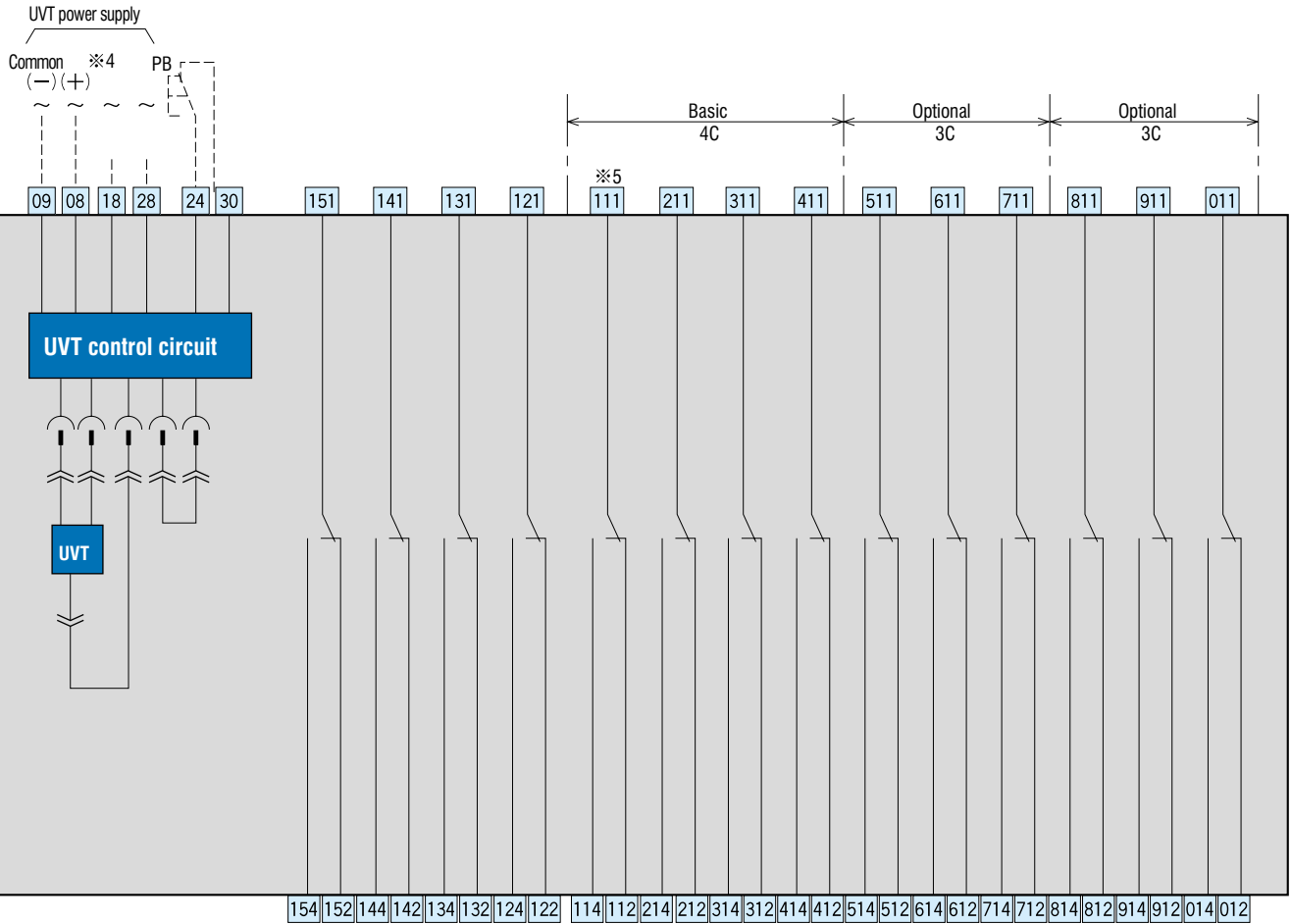

### Designation of terminals for auxiliary and position switches

- \* — \* : Common
- \* : b-contact
- \* : a-contact
- 1: Auxiliary switch
- 2: Position switch (for CONNECTED)
- 3: Position switch (for TEST)
- 4: Position switch (for ISOLATED)
- 5: Position switch (for INSERT)
- (1 - 0: Switch numbers
- A, B, C: Auxiliary switches for microload

CONNECTED position : 121-124 ON  
 121-122 OFF

TEST position : 131-134 ON  
 131-132 OFF

ISOLATED position : 141-144 ON  
 141-142 OFF

INSERT position : 151-154 ON  
 151-152 OFF

For operation sequence of position switches, see page 27.

### Position switches

Top	151	141	131	121
Middle	154	144	134	124
Bottom	152	142	132	122

Top	131	121
Middle	134	124
Bottom	132	122

### Operation/control circuits

01	02	03	04	05	06	07	08	09	10
11	12	13	14	15	16	17	18	19	20
21	22	23	24	25	26	27	28	29	30

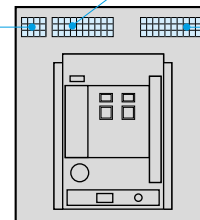

### Auxiliary switches

(4c + optional 6c arrangement)

111	211	311	411	511	611	711	811	911	011
114	214	314	414	514	614	714	814	914	014
112	212	312	412	512	612	712	812	912	012

(4c arrangement)

111	211	311	411
114	214	314	414
112	212	312	412

[31][32][33][34][35][36][37][38][39][40][41][42] Manual connection

If the ground fault protection on the line side or communication function is incorporated, control circuit terminals are of manual connection type.



# Circuit Diagram (with AGR-22B, 31B Protection Relay)

Main circuit

Main circuit voltage for RPT and Monitoring power

Control power

Operation

※3 Motor charging/ Operation circuit

Continuously-rated shunt trip

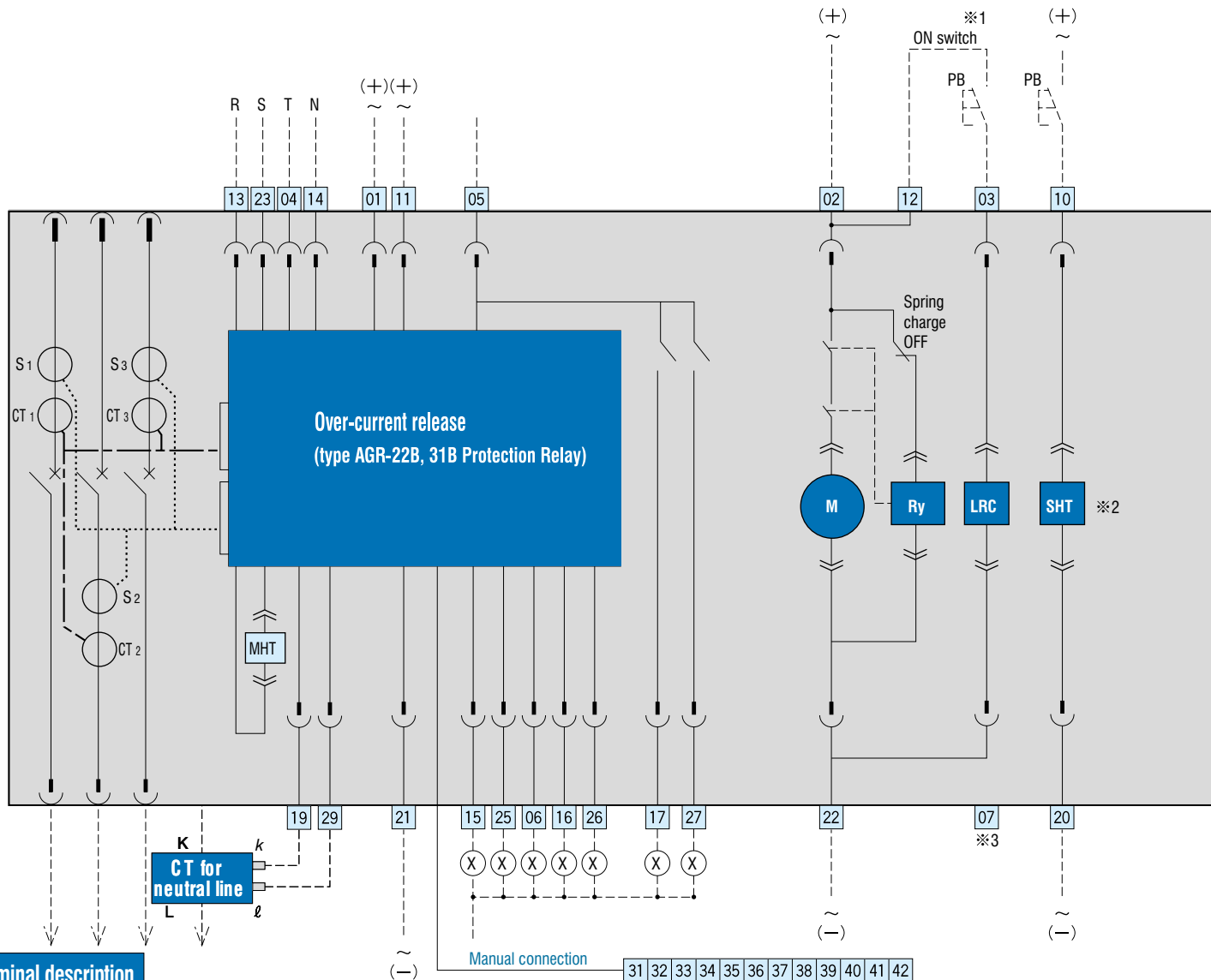

## Terminal description

Check protection relay voltage before connecting.

- 01 21 Control power supply AC200 - 240V, DC200 - 250V, DC48V
- 01 11 Control power supply AC100 - 120V
- 11 21 Control power supply DC100 - 125V, DC24V
- 02 22 Control power supply AC100 - 240V, DC100 - 250V, DC24V, DC48V
- 12 Operation switch, common
- 03 ON switch
- 05 Operation indication terminal, common
- 15 LT trip indication
- 25 ST, INST trip indication
- 06 PTA indication
- 16 GF trip indication or RPT trip indication or ELT trip indication
- 26 System alarm indication
- 17 REF, OH, NS, UFOF or trip indication
- 27 PTA2, UV, OV or spring charge indication
- 10 20 Continuously-rated shunt trip
- 19 Separate CT for neutral line (K)

- 29 Separate CT for neutral line (ℓ)
- 08, 18, 28 UVT power supply
- 09 UVT power supply common
- 35 Separate CT for REF (k)
- 36 Separate CT for REF (ℓ)
- 41 Communication line (-)
- 42 Communication line (+)
- 32 Communication line (common)

### • Do not exceed specified voltages

#### UVT power supply

Term. No.	AC 100V unit	AC 200V unit	AC 400V unit	AC 450V unit
08 - 09	100V	200V	380V	450V
18 - 09	110V	220V	415V	480V
28 - 09	120V	240V	440V	400V

Term. No.	DC 24V unit	DC 48V unit	DC 100V unit	DC 110V unit
08 - 09	24V	48V	100V	110V

## Symbols for accessories

- CT1 - CT3 : Power CTs
- S1 - S3 : Current sensors
- M : Charging motor
- LRC : Latch release coil
- MHT : Magnetic Hold Trigger
- ⊖ Isolating terminal connector (for draw-out type)
- ⊖ Manual connector
- User wiring
- ⊖(X) Relay or indicator lamp

- ※1: Do not connect "b" contact of auxiliary switch to ON switch in series, otherwise, pumping may occur.
  - ※2: See page 30 for the circuit diagram of the continuously-rated shunt trip device with capacitor trip device.
  - ※3: For motor split circuit, terminals 02, 22 and 03, 07 are used for charging and closing operation respectively. (Please specify when ordering)
  - ※4: Refer to page 31 (short pulse only)
  - ※5: Only one of terminals 08, 18, 28 must be used as this is a single phase UVT.
  - ※6: Do not use these terminals for other circuits when both instantaneously rated shunt trip and UVT are fitted. These terminals are used by Terasaki as the anti-burnout SW for the instantaneously rated shunt trip.
- Note: In case of a UVT and a Shunt fitted together or Double opening or closing coil, use an aux. switch to prevent burnout. Contact TERASAKI for wiring.



# Circuit Diagram (with AGR-22B, 31B Protection Relay)

## Undervoltage trip

## Position switches

## Auxiliary switches

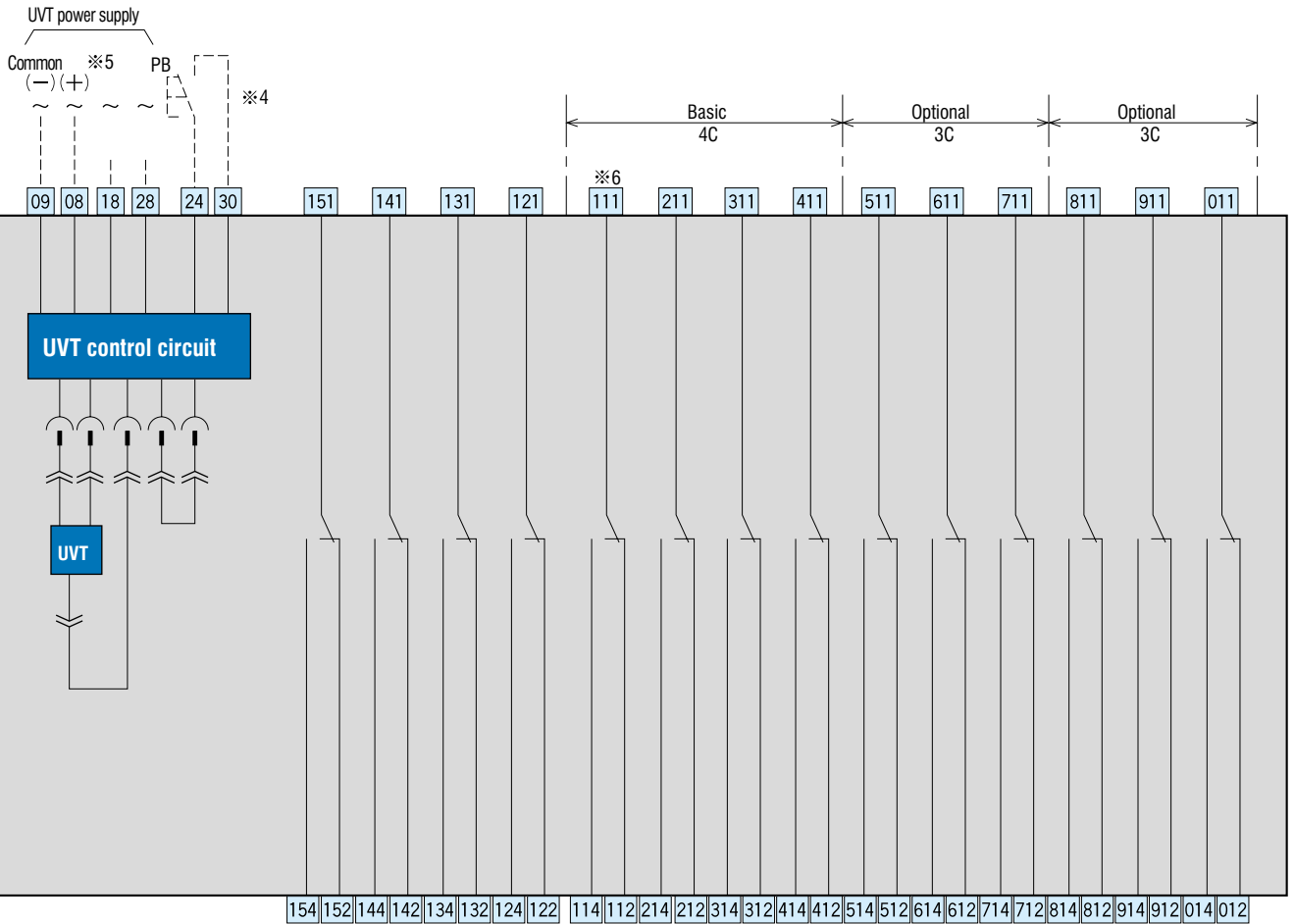

### Designation of terminals for auxiliary and position switches

- \* 1: Common
- \* 2: b-contact
- \* 4: a-contact
- 1: Auxiliary switch
- 2: Position switch (for CONNECTED )
- 3: Position switch (for TEST)
- 4: Position switch (for ISOLATED)
- 5: Position switch (for INSERT)
- ( 1 - 0: Switch numbers
- A, B, C: Auxiliary switches for microload

CONNECTED position : 121-124 ON  
 121-122 OFF  
 TEST position : 131-134 ON  
 131-132 OFF  
 ISOLATED position : 141-144 ON  
 141-142 OFF  
 INSERT position : 151-154 ON  
 151-152 OFF

For operation sequence of position switches, see page 27.

### Position switches

Top	151	141	131	121
Middle	154	144	134	124
Bottom	152	142	132	122

Top	131	121
Middle	134	124
Bottom	132	122

### Operation/control circuits

01	02	03	04	05	06	07	08	09	10
11	12	13	14	15	16	17	18	19	20
21	22	23	24	25	26	27	28	29	30

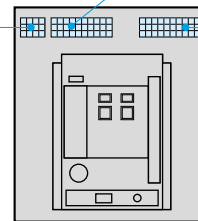

### Auxiliary switches

(4c + optional 6c arrangement)

111	211	311	411	511	611	711	811	911	011
114	214	314	414	514	614	714	814	914	014
112	212	312	412	512	612	712	812	912	012

(4c arrangement)

111	211	311	411
114	214	314	414
112	212	312	412

31 32 33 34 35 36 37 38 39 40 41 42 Manual connection

If the ground fault protection is incorporated and a separate current transformer for neutral line is used, or any one of ground fault protection on the line side, zone interlock or communication function is incorporated, control circuit terminals are of manual connection type.



# Technical Data

## SECTION

## 5

▶ <b>Dielectric strength</b> .....	84
▶ <b>Discrimination</b> .....	85-88



## Dielectric strength

Circuit		Withstand voltage (at 50/60 Hz)		Rated impulse withstand voltage $U_{imp}$
Main circuit		Between terminals, terminal group to earth	AC3500V for 1 minute	12kV
Control circuits	Auxiliary switches	For general service	Terminal group to earth	AC2500V for 1 minute
		For microload	Terminal group to earth	AC2000V for 1 minute
	Position switches	Terminal group to earth	AC2000V for 1 minute	
	Over-current release (OCR)	Terminal group to earth	AC2000V for 1 minute	
	Power supply for undervoltage/reverse power trip function	Terminal group to earth	AC2500V for 1 minute	
Other accessories		Terminal group to earth	AC2000V for 1 minute	4kV

Note: The values shown above are those measured on phase connections and cannot be applied to control terminals on the ACB.

## Internal resistance and power consumption

### • Standard Series

Type	AR208S	AR212S	AR216S	AR220S	AR325S	AR332S	AR440SB	AR440S	AR650S	AR663S
Rated current (A)	800	1250	1600	2000	2500	3200	4000	4000	5000	6300
DC internal resistance per pole (mΩ)	0.033	0.033	0.028	0.024	0.014	0.014	0.017	0.014	0.012	0.010
Power consumption for 3 poles (W)	64	155	215	288	263	430	816	672	900	1190

### • High fault Series

Type	AR212H	AR216H	AR220H	AR316H	AR320H	AR325H	AR332H	AR420H	AR440H	AR663H
Rated current (A)	1250	1600	2000	1600	2000	2500	3200	2000	4000	6300
DC internal resistance per pole (mΩ)	0.024	0.024	0.024	0.014	0.014	0.014	0.014	0.014	0.014	0.010
Power consumption for 3 poles (W)	113	184	288	108	168	263	430	168	672	1190

Note: Above figures are based on the calculation of  $3I^2R$ . For more information please contact TERASAKI.

## Temperature De-rating

Ambient temperature 40 °C

Based Standard	JIS C 8201-2-1 Ann.1 Ann.2 IEC60947-2, EN60947-2 AS3947.2			ANSI C37.13 NEMA, SG-3		
	Terminal arrangement			Terminal arrangement		
Type	Horizontal terminals	Vertical terminals	Front connections	Horizontal terminals	Vertical terminals	Front connections
AR208S	800	800	800	800	800	800
AR212S	1250	1250	1250	1250	1250	1250
AR216S	1600	1600	1600	1540	1600	1570
AR220S	2000	2000	2000	1670	2000	1830
AR325S	2430	2500	2500	2230	2500	2430
AR332S	2790	3200	3150	2700	3200	2890
AR440SB	—	4000	—	—	3310	—
AR440S	—	4000	—	—	3700	—
AR650S	—	5000	—	—	4700	—
AR663S	—	6300	—	—	5680	—
AR212H	1250	1250	—	1250	1250	—
AR216H	1600	1600	—	1540	1600	—
AR220H	2000	2000	—	1670	2000	—
AR316H	1600	1600	—	1600	1600	—
AR320H	2000	2000	—	2000	2000	—
AR325H	2430	2500	—	2230	2500	—
AR332H	2790	3200	—	2700	3200	—
AR420H	—	2000	—	—	※	—
AR440H	—	4000	—	—	3700	—
AR663H	—	6300	—	—	5680	—

Note 1: If different type of terminal arrangement are used for line and load sides refer to the ratings for the horizontal terminals.

Note 2: Front connection can not be specified with the different types of terminal arrangement for line and load sides.

※: Contact TERASAKI for details.



## Derating

### • Standard Series

Based Standards	Ambient temperature (°C)	Type Connecting bar sizes	AR208S	AR212S	AR216S	AR220S	AR325S	AR332S	AR440SB	AR440S	AR650S	AR663S
			2X50X5t	2X80X5t	2X100X5t	3X100X5t	2X100X10t	3X100X10t	4X150X10t	4X150X6t	3X200X10t	4X200X10t
JIS C 8201-2-1 Ann.1 Ann.2 IEC60947-2 EN 60947-2 AS3947.2	40 (Standard ambient temperature)		800	1250	1600	2000	2500	3200	4000	4000	5000	6300
	45		800	1250	1600	2000	2500	3200	4000	4000	5000	6300
	50		800	1250	1600	2000	2500	3200	3940	4000	4950	6000
	55		800	1200	1540	1820	2500	2990	3820	3940	4710	5680
	60		800	1150	1460	1740	2400	2850	3690	3760	4450	5370
NEMA, SG-3 ANSI C37.13	40 (Standard ambient temperature)		800	1250	1540	2000	2500	3200	3310	3700	4700	5680
	45		800	1190	1470	1960	2500	3010	3200	3580	4450	5370
	50		800	1130	1390	1860	2440	2860	3100	3470	4180	5050
	55		790	1070	1310	1750	2300	2690	2980	3350	3900	4710
	60		740	1000	1230	1640	2150	2520	2870	3140	3610	4350

Note: The values are applicable for both Draw-out type and Fixed type.

The values of AR208S, AR212S and AR216S are for horizontal terminals on both line and load side.

The values of AR220S, AR325S, AR332S, AR440SB, AR440S, AR650S and AR663S are for vertical terminals on both line and load side.

Above figures are subject to the design of the enclosure and rating of busbar.

### • High fault Series

Based Standards	Ambient temperature (°C)	Type Connecting bar sizes	AR212H	AR216H	AR220H	AR316H	AR320H	AR325H	AR332H	AR420H	AR440H	AR663H
			2X80X5t	2X100X5t	3X100X5t	2X100X5t	3X100X5t	2X100X10t	3X100X10t	3X100X5t	4X150X6t	4X200X10t
JIS C 8201-2-1 Ann.1 Ann.2 IEC60947-2 EN 60947-2 AS3947.2	40 (Standard ambient temperature)		1250	1600	2000	1600	2000	2500	3200	2000	4000	6300
	45		1250	1600	2000	1600	2000	2500	3200	2000	4000	6300
	50		1250	1600	2000	1600	2000	2500	3200	2000	4000	6000
	55		1250	1600	1820	1600	2000	2500	2990	2000	3940	5680
	60		1250	1550	1740	1600	2000	2400	2850	2000	3760	5370
NEMA, SG-3 ANSI C37.13	40 (Standard ambient temperature)		1250	1600	2000	1600	2000	2500	3200	2000	3700	5680
	45		1250	1600	1960	1600	2000	2500	3010	2000	3580	5370
	50		1250	1600	1860	1600	2000	2440	2860	2000	3470	5050
	55		1250	1510	1750	1600	1950	2300	2690	2000	3350	4710
	60		1240	1420	1640	1550	1830	2150	2520	2000	3140	4350

Note: The values are applicable for both Draw-out type and Fixed type.

The values are for vertical terminals on both line and load side.

Above figures are subject to the design of the enclosure and rating of busbar.



Discrimination, also called selectivity, is the co-ordination of protective devices such that a fault is cleared by the protective device installed immediately upstream of the fault, and by that device alone.

### Total discrimination

Discrimination is said to be total if the downstream circuit breaker opens and the upstream circuit breaker remains closed. This ensures maximum availability of the system.

### Partial discrimination

Discrimination is partial if the above condition is not fulfilled up to the prospective short circuit current, but to a lesser value, termed the selectivity limit current ( $I_S$ ).

Above this value both circuit breakers could open, resulting in loss of selectivity.

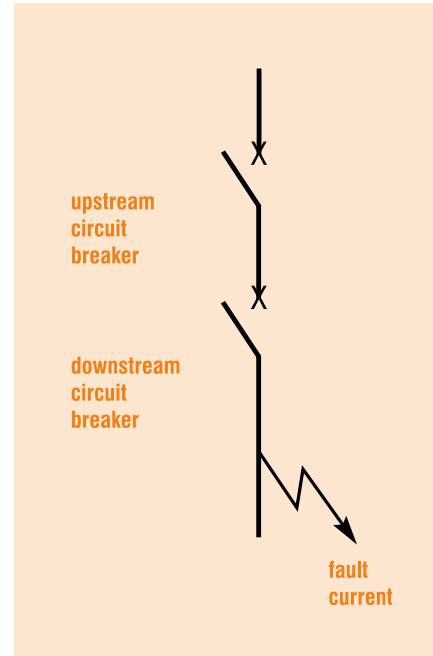

## How to Read the Discrimination Tables

Boxes containing the letter “T” indicate total discrimination between the relevant upstream and downstream circuit breakers. Total discrimination applies for all fault levels up to the breaking capacity of the upstream or the downstream circuit breaker, whichever is the lesser.

For the other boxes, discrimination is either partial or there is no discrimination

### Worked Examples



**A main switchboard requires a 1600A ACB feeding a 400A MCCB. The fault level is 65kA. What combination of protective devices would provide total discrimination?**



**A TemPower 2 ACB AR216S feeding a TemBreak2 S400GJ would provide total discrimination up to 65kA. See page 87.**

Note: Discrimination would be total whether the **TemPower 2** ACB had an integral or external protection relay because  $(1s) = I_{CS}$  Most other ACBs have  $I_{CW} (1s) < I_{CS}$ .



Upstream: **TemPower 2 ACB** with or without Integral Protection Relay

Downstream: **TemBreak 2 MCCB**

Frame	Model	Breaking Capacity	800A			1250A			1600A			2000A			2500A		3200A		4000A	5000A	6300A	
			AR208S	AR212S	AR212H	AR216S	AR216H	AR316H	AR220S	AR220H	AR320H	AR325S	AR325H	AR332S	AR332H	AR440SB	AR650S	AR663S	AR663H			
			65kA	65kA	80kA	65kA	80kA	100kA	65kA	80kA	100A	85kA	100kA	85kA	100kA	100kA	120kA	120kA	135kA			
Downstream MCCB	125A	E125NJ 25kA	T	T	T	T	T	T	T	T	T	T	T	T	T	T	T	T	T	T	T	
		S125NJ 36kA	T	T	T	T	T	T	T	T	T	T	T	T	T	T	T	T	T	T	T	T
		S125GJ 65kA	T	T	T	T	T	T	T	T	T	T	T	T	T	T	T	T	T	T	T	T
		H125NJ 125kA	T	T	T	T	T	T	T	T	T	T	T	T	T	T	T	T	T	T	T	T
		L125NJ 200kA	T	T	T	T	T	T	T	T	T	T	T	T	T	T	T	T	T	T	T	T
	160A/ 250A	S160NJ 36kA	T	T	T	T	T	T	T	T	T	T	T	T	T	T	T	T	T	T	T	T
		S160GJ 65kA	T	T	T	T	T	T	T	T	T	T	T	T	T	T	T	T	T	T	T	T
		E250NJ 25kA	T	T	T	T	T	T	T	T	T	T	T	T	T	T	T	T	T	T	T	T
		S250NJ 36kA	T	T	T	T	T	T	T	T	T	T	T	T	T	T	T	T	T	T	T	T
		S250GJ 65kA	T	T	T	T	T	T	T	T	T	T	T	T	T	T	T	T	T	T	T	T
		S250PE 70kA	T	T	T	T	T	T	T	T	T	T	T	T	T	T	T	T	T	T	T	T
		H250NJ 125kA	T	T	T	T	T	T	T	T	T	T	T	T	T	T	T	T	T	T	T	T
		L250NJ 200kA	T	T	T	T	T	T	T	T	T	T	T	T	T	T	T	T	T	T	T	T
	400A/ 630A	E400NJ 25kA	T	T	T	T	T	T	T	T	T	T	T	T	T	T	T	T	T	T	T	T
		S400CJ 36kA	T	T	T	T	T	T	T	T	T	T	T	T	T	T	T	T	T	T	T	T
S400NJ 50kA		T	T	T	T	T	T	T	T	T	T	T	T	T	T	T	T	T	T	T	T	
S400NE 50kA		T	T	T	T	T	T	T	T	T	T	T	T	T	T	T	T	T	T	T	T	
S400GJ 70kA		T	T	T	T	T	T	T	T	T	T	T	T	T	T	T	T	T	T	T	T	
S400GE 70kA		T	T	T	T	T	T	T	T	T	T	T	T	T	T	T	T	T	T	T	T	
S400PJ 85kA		T	T	T	T	T	T	T	T	T	T	T	T	T	T	T	T	T	T	T	T	
S400PE 85kA		T	T	T	T	T	T	T	T	T	T	T	T	T	T	T	T	T	T	T	T	
H400NJ 125kA		T	T	T	T	T	T	T	T	T	T	T	T	T	T	T	T	T	T	T	T	
H400NE 125kA		T	T	T	T	T	T	T	T	T	T	T	T	T	T	T	T	T	T	T	T	
E630NE 36kA		T	T	T	T	T	T	T	T	T	T	T	T	T	T	T	T	T	T	T	T	
S630CE 50kA		T	T	T	T	T	T	T	T	T	T	T	T	T	T	T	T	T	T	T	T	
S630GE 70kA		T	T	T	T	T	T	T	T	T	T	T	T	T	T	T	T	T	T	T	T	
800A	S800-CJ 36kA	T	T	T	T	T	T	T	T	T	T	T	T	T	T	T	T	T	T	T	T	
	S800-NJ 50kA	T	T	T	T	T	T	T	T	T	T	T	T	T	T	T	T	T	T	T	T	
	S800-RJ 70kA	T	T	T	T	T	T	T	T	T	T	T	T	T	T	T	T	T	T	T	T	
	S800-NE 50kA	T	T	T	T	T	T	T	T	T	T	T	T	T	T	T	T	T	T	T	T	
	S800-RE 70kA	T	T	T	T	T	T	T	T	T	T	T	T	T	T	T	T	T	T	T	T	
	H800-NE 125kA	T	T	T	T	T	T	T	T	T	T	T	T	T	T	T	T	T	T	T	T	
	L800-NE 200kA	T	T	T	T	T	T	T	T	T	T	T	T	T	T	T	T	T	T	T	T	
1000A	S1000-SE 50kA	-	T	T	T	T	T	T	T	T	T	T	T	T	T	T	T	T	T	T	T	
	S1000-NE 70kA	-	T	T	T	T	T	T	T	T	T	T	T	T	T	T	T	T	T	T	T	
1250A	S1250-SE 50kA	-	T	T	T	T	T	T	T	T	T	T	T	T	T	T	T	T	T	T	T	
	S1250-NE 70kA	-	T	T	T	T	T	T	T	T	T	T	T	T	T	T	T	T	T	T	T	
	S1250-GE 100kA	-	T	T	T	T	T	T	T	T	T	T	T	T	T	T	T	T	T	T	T	
1600A	S1600-SE 50kA	-	-	-	T	T	T	T	T	T	T	T	T	T	T	T	T	T	T	T	T	
	S1600-NE 100kA	-	-	-	T	T	T	T	T	T	T	T	T	T	T	T	T	T	T	T	T	

Notes: 1. All ACB's have li set at NON, MCR ON.  
 2. Assuming ACB time settings are greater than MCCB.  
 3. The above table is in accordance with IEC 60947-2, Annex A.

4. External relay can be used - Contact Terasaki for further details.  
 5. All values shown at 400V AC.

T= Total Selectivity



## Discrimination with 'T' type fuses

The following table should be used as a guide when selecting Terasaki TemPower 2 Air Circuit Breakers and fuses (BS88/IEC60260) which are immediately downstream from a transformer.

$I_n$  and  $I_R$  are set to the full rated current of the transformer, and  $t_R$ ,  $I_{sd}$  and  $t_{sd}$  are at standard transformer settings. Listed are the maximum fuse ratings that can be used when downstream from a given ACB at these settings.

Also included are the maximum fuse ratings that can be used downstream when  $t_R$ ,  $I_{sd}$  and  $t_{sd}$  are at their maximum settings.

All information listed is based on a transformer secondary voltage of 415V.

TRANSFORMER	kVA	5	630	750	800	1000	1250	1600	2000
	F.L.C. (A)	696	876	1043	1113	1391	1739	2226	2782
TemPower 2	Type	<b>AR208S</b>	<b>AR212S</b>	<b>AR212S</b>	<b>AR212S</b>	<b>AR216S</b>	<b>AR220S</b>	<b>AR325S</b>	<b>AR332S</b>
	C.T. (A)	800	1250	1250	1250	1600	2000	2500	3200
SETTINGS (AGR-L)	$I_n$	1	0.8	1	1	1	1	1	1
	$I_R$	0.9	0.9	0.85	0.9	0.9	0.9	0.9	0.9
	$t_R$ (sec)	20	20	20	20	20	20	20	20
	$I_{sd}$	6	6	6	6	6	6	6	6
	$t_{sd}$ (msec)	400	400	400	400	400	400	400	400
Max. fuse rating with standard ACB settings	Note: 1 (Amps)	355	400	500	500	500	630	800	1000
Max. fuse rating with maximum ACB settings	(Amps)	450	500	670	710	800	1000	1250	1250 Note:2

> The above 'In' settings are based on 100% of Rated Current (Ict).

> Table Reference :  $I_R$  - Long Time Delay Pickup Current,  $t_R$  - Long Time Delay Time Setting,  $I_{sd}$  - Short Time Delay Pickup Current,  $t_{sd}$  - Short Time Delay Time Setting.

### Notes:

Note:1 It is possible to increase the maximum fuse rating by utilising the 'ramp' facility on the on the **TemPower2** Protection Relay (AGR).

Note:2 Information on fuses above 1250A rating was not available.

Note:3 All ACBs have  $I_i$  (Instantaneous) set to NON. (MCR can be set to ON)

Please note the above table is meant only for guidance, individual installations should have a specific discrimination study undertaken.

# Useful related products and services

## SECTION

## 6

▶	<b>External Control and Monitoring Devices for ACBs</b> .....	90-91
▶	<b>Life-cycle Services</b> .....	92-93
▶	<b>Circuit Breaker Selectivity Software</b> .....	94



## Monitoring and Communication: T2ED

T2ED is a new Terasaki external display for **TemPower 2** ACBs and TemBreak 2 MCCBs. It displays circuit measurements and information about the installed breaker in an easily readable way. T2ED may be used as a stand-alone local display. T2ED is also able to transfer all this information directly to a Modbus network.

### Special Features:

View circuit values and breakers data safely from the outside

- Easy direct connection from breaker to T2ED (no need for communication module)
- Easy direct connection from T2ED to Modbus (no need for communication module)
- Analogue, numerical and bar graph views

### Technical Characteristics:

- Rated voltage: DC24V (Applicable range of voltage: DC18 to DC 31V)
- Consumption (at DC24V): 50mA
- Dimensions (96 x 96 x 50) mm
- Serial Interface: RS485
- Protocol: Modbus-RTU
- Transmission method: Two-wire half duplex

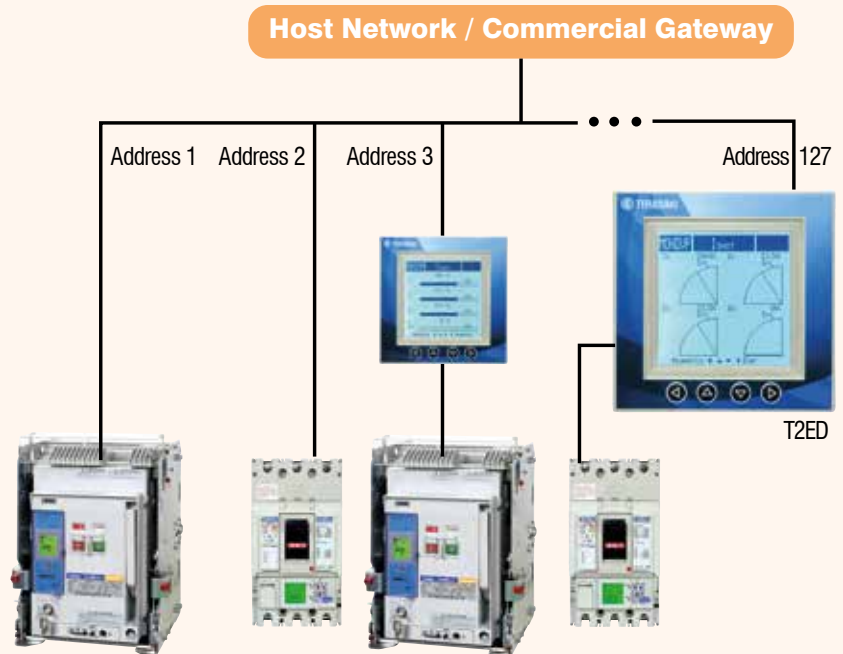

## Multi-Protection Relay: TemTrip 2

TemTrip2 is a multi-protection relay for medium or low voltage circuit breakers that is capable of indicating via LEDs that the load current is picked up or the breaker trips open and showing various information including the phase current, line voltage and fault current on the LCD.



The relay is available in three types: for generator protection, feeder circuit protection and transformer protection.

### Special Features:

- Multi-protection
- Ground fault detection via zero-phase voltage
- Directional ground fault detection
- Ratio differential characteristic
- Reverse power trip
- Readout of trip/ alarm cause
- Internal clock
- Self-diagnostic

		PRR-1H-G	PRR-1H-F	PRR-1H-T
		Generator protection	Feeder circuit	Transformer protection
Adjustable long time-delay trip	LT	○	○	○
Adjustable short time-delay trip	ST	○	○	○
Adjustable instantaneous trip	INST	○	○	○
Adjustable undervoltage trip	UV(27)	○	◆	-
Adjustable overvoltage trip	OV(59)	○	◆	-
Adjustable reverse power trip	RP(67R)	○	-	-
Adjustable ground fault trip	Overvoltage ground OVGR(64)	○	○	○
	Directional ground DGR(67G)	○	○	○
Ratio differential trip	DIFF(87G)	○	-	-
	(87T)	-	-	○
Pre-trip alarm	(PTA)	○	○	○
	PTA2	○	-	-

○Standard ◆Optional

6



## TemTransfer 3 Automatic Changeover Controller for TemPower 2 ACBs, TemBreak 2 MCCBs and TemContact 2 Contactors

TemTransfer 3 is an Automatic Transfer Switch Controller. The TemTransfer 3 will monitor the voltage and frequency of the AC supply from two different sources, which could be from both generator or mains (utility), or a combination of both.

The module will monitor S1 (source 1) and in the event of a failure will issue a start command to S2 (source 2).

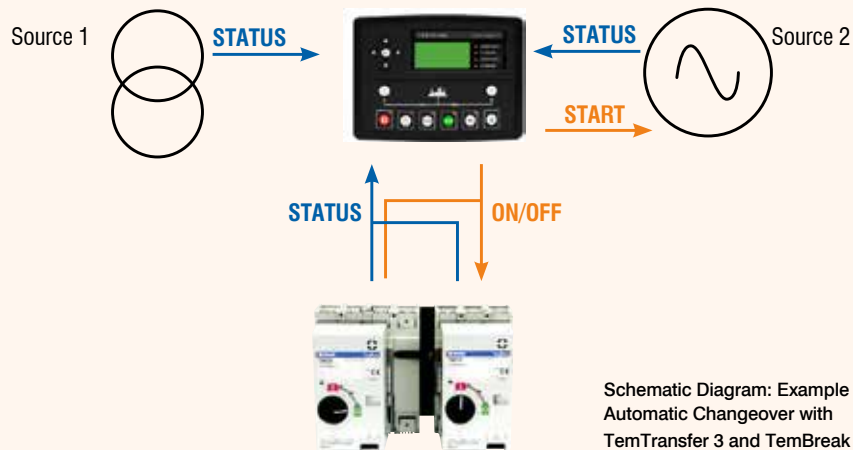

## Earth Leakage Protection Relays

Terasaki TemProtect monitoring and control devices provide earth leakage protection and monitoring for most industrial and commercial applications. They are used to monitor earth currents to protect electrical equipment and personnel against dangers such as electric faults.

TemProtect has been designed to be as flexible as possible to suit a wide range of applications. The range includes Din Rail, Panel or base mount versions, relays suitable for use in AC systems (unaffected by DC components which may be present).

All relays comply with international standards including IEC 60255.

ELR-1E



Flush mounted DIN 96x96x60mm unit

ELRC-1



Relay with built-in Toroidal Transformer Space Saving

ELR-3C



DIN rail mounted unit (DIN 43880 standard) the three modules width 17.5mm

CTM



Supervision Relay monitors circuit breakers tripping circuit

ELR-3B



Residual Current Protection Relay/Monitor

- Adjustable tripping current and time delay setting
- Selectable automatic or manual reset facility
- Adjustable time/current multiplier setting
- Test button
- LEDs to indicate the units status



Retrofitting refers to the addition of new technology to older systems. Retrofit ACBs can replace ageing, unsafe switches and circuit breakers.

## Top 5 reasons to use Retrofit

### 1. Improve safety and functionality

Modern circuit breakers offer safety interlocks, remote switching and circuit monitoring.

### 2. Optimise existing plant

Static components in a switchboard (the steelwork and busbar system) can be retained. Only the functional, moving parts (the circuit breakers) are replaced. Retrofitting is typically 80% cheaper than switchboard replacement with minimum downtime.

### 3. Guaranteed spares availability

Terasaki guarantee spare parts availability for at least 10 years after the withdrawal from sale of a circuit breaker.

### 4. Modernise the protection system

Old protection relays can be removed and replaced with modern microprocessor protection which is integral to the ACB with automatic plc controls.

### 5. Reduce arc flash hazard

Modern ACBs clear short-circuits much faster than older types. This means that the incident arc energy is correspondingly lower.

## Terasaki's Retrofit Services

We prefer to conduct a site survey for every retrofit project - even if the breaker to be replaced is already on our design database. This ensures that the installation is as quick as possible, with minimum disruption to the client's supply.

Mechanical and electrical interfaces are modelled using state-of-the-art 3-D CAD.

Manufacture, assembly and routine testing is carried out at Terasaki's facility in Glasgow, Scotland. The factory and processes are certified to the ISO 9001 quality management standard.

Some of our Retrofit designs can be installed without a shutdown. Where this is not possible, our team will ensure that disruption is minimised.



**VERIFIED**

### Verified Designs

Third Party Technical Report.

### Tested to current standard

ASTA tested to IEC 61439 for short-circuit withstand (Icw)  
GEC MPact  
Ellison  
English Electric

### Low voltage arc hazard reduction

1. Remove switching using umbilical cord controller
2. Faster opening time reduces incident arc energy. **TemPower 2** ACB can be set to open a short-circuit in less than 30 milliseconds (typically at least twice as fast as the device it will replace).

### Modern protection

The AGR Protection relay can replace the functions of several devices in an existing switchboard to provide:

- restricted earth fault protection
- overcurrent protection
- data communication to BMS or SCADA
- plc control

We design retrofit ACBs on request. If you are interested in a brand which is not shown below we would be happy to examine it. New designs are continually added to our portfolio. Check the latest list on the Terasaki website: [www.terasaki.co.uk](http://www.terasaki.co.uk)

- Terasaki
- Ellison
- GEC
- Merlin Gerin
- Siemens
- Unelec
- Square D
- Mitsubishi
- Sace
- ABB
- Hyundai
- AEG
- English Electric
- MEM
- Klockner Moeller



## Retrofit Case Study

### Terasaki Retrofit Project Reference

**Client:** Royal Bank of Canada  
**Project:** Retrofit  
**Location:** 71 Queen Victoria Street, London  
**Retrofit:** 24 x Merlin Gerin Selpact 1000A  
 3 x Merlin Gerin DA 4000A  
**Type:** to TemPower 2

#### Capability:

- 27 circuit breakers replace by TemPower 2 retrofit ACBs
- Only one week-end shutdown
- No disturbance to switchboard or copperwork
- Safe and fast



Direct Response Engineer Installing Retrofit ACB

## REPLACEMENT OF 27 MERLIN GERIN ACBS WITH TERASAKI ACBS

The main electrical incomer to Royal Bank of Canada’s UK headquarters in London was tripping spuriously and engineers became worried that a sudden and complete failure of the power supply could result. The faulty device, a Merlin Gerin DA 4000 ACB, was obsolete and irreparable. 26 other Selpact and DA 4000 ACBs in the switchboard were also obsolete.

Engineers had permission to shut down the main power supply for only one weekend – not long enough for the switchboard to be replaced or for any modifications to be made to the copperwork.

Terasaki’s Direct Response Service Division had what they needed: a retrofit solution. The Terasaki **TemPower 2** retrofit ACBs were designed to match the connections and mountings of the existing ACBs exactly. There was no need to modify the switchboard and all 27 ACBs were replaced safely and quickly.



DA 4000 ACB:  
Access Restricted Due to Nuisance Tripping

#### Retrofit Details

- Merlin Gerin DA 4000 x 3
- Merlin Gerin Selpact x 24
- Building power down: 10:00 Friday
- 27 Terasaki TemPower 2 retrofit ACBs installed
- Building re-energised 12:00 Sunday



Obsolete Merlin Gerin Selpact ACBs

CTM



## Spares Policy (Circuit Breakers)

Terasaki guarantees availability of breaker spare parts for at least 10 years after the breaker’s withdrawal from sale. Beyond that period the Direct Response Service Division will continue to support older products in the field carrying out routine maintenance and repairs on-site.

The Direct Response Service Division can provide a recommended spares list, based on the specification of all breakers on site. We usually recommend a combination of “complete” and “component” spares.

## Warranty Extension

Terasaki offers one year standard warranty for our breakers. However you can extend it up to 4 or 5 years depending on project requirements.





# *TemCurve Lite 3.0*

TemCurve Lite Selectivity Software can assist in protection device grading from the transformer primary to the point of final distribution. The software is designed for the Terasaki range of circuit breakers, but also includes a large number of complimentary protection devices such as low and high voltage fuses and relays.

### **TemCurve Lite 3.0 is FREE**

- The software package is now multilingual allowing you to select from: English, Italian, Spanish, Russian, Swedish, Chinese and Japanese language options
- It can output DXF and PDF files
- Latest product developments included: TemBreak 2 Lite MCCBs and TemBreak 2 CBRs.





# TemPower 2 Order Form

## Fixed and Drawout Pattern ACB's AR208 to AR663 (800A to 6300A)

COMPANY NAME:	EMAIL ADDRESS:
CONTACT NAME:	ORDER NUMBER:
TELEPHONE NUMBER:	QUANTITY:
FAX NUMBER:	DELIVERY TIME REQUEST :

### 1. TemPower 2 ACB: Enter your choice in the boxes provided (Refer to the catalogue for ratings and specifications)

TERASAKI ACB TYPE  AR  FOR EXAMPLE - AR

ENTER CIRCUIT BREAKER TYPE - Type S, H or SB

ENTER RATED CURRENT - Amps

ENTER SENSOR KIT RATING - Ict

ENTER NUMBER OF POLES

\*H TYPES ARE ONLY AVAILABLE ON 1250A TO 3200A ACBS AND 'SB' TYPE ON THE 4000A ACB

ONLY ENTER A V ONLY ENTER A VALUE IF DIFFERENT FROM RATED CURRENT

### 2. Mounting, Connections, Shutters and System Type: Select required boxes.

Fixed Pattern.  Not available on AR4 & AR6 ACBs Drawout Pattern.

	Horizontal	Vertical	Front
Top - Connections.	<input type="checkbox"/>	<input type="checkbox"/>	<input type="checkbox"/>
Bottom - Connections.	<input type="checkbox"/>	<input type="checkbox"/>	<input type="checkbox"/>

For AR4 & AR6 ACBs only vertical connections are available

Control Circuit Terminal Cover

Main Circuit Shutters

Control Circuit Shutters

System Voltage  V 3 Phase/3 Wire  3 Phase/4 Wire  If the system type is not selected we will assume 415V 3P/4W

### 3. AGR - Protection Relay and Protection Options: Tick required boxes.

Non Automatic.  Go to Section 4 - Indication

Protection Functions	AGR-11B	AGR-21/22B				AGR-31B (xxH)			
	Economy Protection - Dial	Standard Protection - LCD				Enhanced Protection - LCD			
	AGR-11BL	AGR-21BL	AGR-21BR	AGR-21BS	AGR-22BS	AGR-31BL	AGR-31BR	AGR-31BS	----
AL		----	----	----	----	----	----	----	----
AS		----	----	----	----	----	----	----	----
PS	----								
GL**		----	----	----	----	----	----	----	----
GS		----	----	----	----	----	----	----	----
PG		----	----	----	----	----	----	----	----
PR		----	----	----	----	----	----	----	----

#### Protection Options

Neutral Phase Protection - NP.									
Mechanical Reset - M (Only AS and GS type)									
S1-Contact Temperature Monitoring - OH.					N2	N2	N2	N2	
S1-Trip Indicator.		N2	N2		N2	N2	N2	N2	
S1-Phase Rotation Protection - NS.		N2	N2						
S1-Restricted Ground Fault - REF. N4		N2	N2						
S2-Second Pre-Trip Alarm - PTA2.					N3			N3	
S2-Undervoltage Alarm - UVA.					N3	N3	N3	N3	
S2-Over Voltage Alarm, Under/Over Frequency - V						N3	N3	N3	
S2-Spring Charge Indicator.					N3	N3	N3	N3	
Zone Interlock - Z.									
Communication - C.									

For LCD and AS/GS type AGR specify control voltage

AC100-120V	AC200-240V	DC24V	DC48V	DC100-25V	DC200-250V
------------	------------	-------	-------	-----------	------------

#### Example of AGR Protection Relay Description

RELAY KEY

Protection Relay Family.

Protection Relay Group.

Protection Function and Indication.

A = LSI PROTECTION. (as standard on all protection relays)

G = A + UNRESTRICTED GROUND FAULT PROTECTION. All AGR-B Protection Relays have individual operation contact indicators except the AGR-11B, which has a single operation contact indicator.

P = A + PRE TRIP ALARM.

R = A + REVERSE POWER.

AGR BL Type Protection Relay - INDUSTRIAL & TRANSFORMER

AGR BS Type Protection Relay - GENERATOR

AGR BR Type Protection Relay - CHARACTERISTICS TO IEC 60255-3

\*\*For 3 Pole ACBs with ground fault please indicate if external 4th CT is **NOT** required. Not required -

• For BS Relay specify generator full load current (In) if applicable -  Amps

• Back lit LCD for AGR-21B, 22B (option)

NOTES:

N2 - Only one function can be selected from section S1.

N3 - Only one function can be selected from section S2.

N4 - Restricted Ground Fault only available with PG function.



# TemPower 2 Order Form

## Fixed and Drawout Pattern ACB's AR208 to AR663 (800A to 6300A)

### 4. Indication Accessories: Tick required boxes.

4AB Auxiliary Switches  
 7AB Auxiliary Switches  
 10AB Auxiliary Switches

<input type="checkbox"/>
<input type="checkbox"/>
<input type="checkbox"/>

Insert	Isolated	Test	Conn
<input type="checkbox"/>	<input type="checkbox"/>	<input type="checkbox"/>	<input type="checkbox"/>

= Total 2.  
 = Total 4.

Non-Auto Trip Indication Switch-Normal (Not Ready to Close)  
 Non-Auto Spring Charge Switch-Normal Ready to Close Switch

<input type="checkbox"/>
<input type="checkbox"/>
<input type="checkbox"/>

Open/Close Cycle Counter

### 5. Electrical Operation Accessories: Tick required boxes.

Double Closing Coil 24V DC & 240V AC Only (Short Rated)  
 Double Shunt Trip Coil 24V DC & 240 V AC Only (Short Rated)  
 Split Circuit\*\* (For Motor and Closing Coil)

<input type="checkbox"/>
<input type="checkbox"/>
<input type="checkbox"/>

Capacitor Shunt Trip 110 AC (Not Available with UVT)

\*\*Split Circuit - Voltages for the motor and closing coil must be indicated below.

#### AC - Control Voltage

Shunt Trip Continuously Rated (Short Rated with UVT)  
 Motor Operator and Closing coil  
 Closing Coil (Split Circuit)\*\*  
 Motor Operator (Split Circuit)\*\*  
 Undervoltage Trip Device - Instantaneous  
 Undervoltage Trip Device - Time-Delay

AC100	AC110	AC120	AC200	AC220	AC230	AC240	AC380	AC400	AC415	AC440
<input type="checkbox"/>	<input type="checkbox"/>	<input type="checkbox"/>	<input type="checkbox"/>	<input type="checkbox"/>	<input type="checkbox"/>	<input type="checkbox"/>	<input type="checkbox"/>	<input type="checkbox"/>	<input type="checkbox"/>	<input type="checkbox"/>
<input type="checkbox"/>	<input type="checkbox"/>	<input type="checkbox"/>	<input type="checkbox"/>	<input type="checkbox"/>	<input type="checkbox"/>	<input type="checkbox"/>	<input type="checkbox"/>	<input type="checkbox"/>	<input type="checkbox"/>	<input type="checkbox"/>
<input type="checkbox"/>	<input type="checkbox"/>	<input type="checkbox"/>	<input type="checkbox"/>	<input type="checkbox"/>	<input type="checkbox"/>	<input type="checkbox"/>	<input type="checkbox"/>	<input type="checkbox"/>	<input type="checkbox"/>	<input type="checkbox"/>
<input type="checkbox"/>	<input type="checkbox"/>	<input type="checkbox"/>	<input type="checkbox"/>	<input type="checkbox"/>	<input type="checkbox"/>	<input type="checkbox"/>	<input type="checkbox"/>	<input type="checkbox"/>	<input type="checkbox"/>	<input type="checkbox"/>
<input type="checkbox"/>	<input type="checkbox"/>	<input type="checkbox"/>	<input type="checkbox"/>	<input type="checkbox"/>	<input type="checkbox"/>	<input type="checkbox"/>	<input type="checkbox"/>	<input type="checkbox"/>	<input type="checkbox"/>	<input type="checkbox"/>

#### DC - Control Voltage

Shunt Trip Continuously Rated (Short Rated with UVT)  
 Motor Operator and Closing coil  
 Closing Coil (Split Circuit)\*\*  
 Motor Operator (Split Circuit)\*\*  
 Undervoltage Trip Device - Instantaneous

DC24	DC30	DC48	DC60	DC100	DC110	DC125	DC200	DC220	DC250
<input type="checkbox"/>	<input type="checkbox"/>	<input type="checkbox"/>	<input type="checkbox"/>	<input type="checkbox"/>	<input type="checkbox"/>	<input type="checkbox"/>	<input type="checkbox"/>	<input type="checkbox"/>	<input type="checkbox"/>
<input type="checkbox"/>	<input type="checkbox"/>	<input type="checkbox"/>	<input type="checkbox"/>	<input type="checkbox"/>	<input type="checkbox"/>	<input type="checkbox"/>	<input type="checkbox"/>	<input type="checkbox"/>	<input type="checkbox"/>
<input type="checkbox"/>	<input type="checkbox"/>	<input type="checkbox"/>	<input type="checkbox"/>	<input type="checkbox"/>	<input type="checkbox"/>	<input type="checkbox"/>	<input type="checkbox"/>	<input type="checkbox"/>	<input type="checkbox"/>
<input type="checkbox"/>	<input type="checkbox"/>	<input type="checkbox"/>	<input type="checkbox"/>	<input type="checkbox"/>	<input type="checkbox"/>	<input type="checkbox"/>	<input type="checkbox"/>	<input type="checkbox"/>	<input type="checkbox"/>
<input type="checkbox"/>	<input type="checkbox"/>	<input type="checkbox"/>	<input type="checkbox"/>	<input type="checkbox"/>	<input type="checkbox"/>	<input type="checkbox"/>	<input type="checkbox"/>	<input type="checkbox"/>	<input type="checkbox"/>

### 6. External Accessories: Tick required boxes.

Door Flange IP20  
 Door Flange IP31  
 Standard Drawout Handle  
 Storage Drawout Handle  
 Insertion Prevention Device (Insert Code in Box)  
 InterPole Barriers (Not Applicable for Front Connections)  
 Step Down Transformer (P380-440V/S220V)  
 Tropicalisation Treatment  
 Anti-Corrosion Treatment  
 Cold Climate Treatment  
 Test Report (Enter Number of Copies in Box)

<input type="checkbox"/>
<input type="checkbox"/>
<input type="checkbox"/>
<input type="checkbox"/>
<input type="checkbox"/>
<input type="checkbox"/>
<input type="checkbox"/>
<input type="checkbox"/>
<input type="checkbox"/>
<input type="checkbox"/>
<input type="checkbox"/>
<input type="checkbox"/>
<input type="checkbox"/>
<input type="checkbox"/>
<input type="checkbox"/>

IP55 Transparent Cover  
 Fixing Blocks  
 Test Jumper  
 Auto-Discharge  
 Lifting Plates  
 Protection relay Checker ANU-1  
 Protection relay test interface unit ANU-2  
 Main Shutter Padlock Device  
 IP3X Chassis Protection

<input type="checkbox"/>
<input type="checkbox"/>
<input type="checkbox"/>
<input type="checkbox"/>
<input type="checkbox"/>
<input type="checkbox"/>
<input type="checkbox"/>
<input type="checkbox"/>
<input type="checkbox"/>
<input type="checkbox"/>
<input type="checkbox"/>
<input type="checkbox"/>
<input type="checkbox"/>
<input type="checkbox"/>
<input type="checkbox"/>

Lifter Loader

AWR-1B  
 AWR-2B

<input type="checkbox"/>
<input type="checkbox"/>

For AR 2, 3 & 440SB  
 For AR 2, 3, 4 & 6

### 7. Locking and Interlocking Systems: Tick required boxes.

Horizontal Mechanical Interlock for three ACBs, Gen. ACB Interlocked with outer ACBs  
 Horizontal Mechanical Interlock for three ACBs, one or two from three  
 Horizontal Mechanical Interlock for two ACBs, one from two  
 Horizontal Mechanical Interlock for three ACBs, one from three

Type A (4)	<input type="checkbox"/>
Type B (2)	<input type="checkbox"/>
Type C (1)	<input type="checkbox"/>
Type D (3)	<input type="checkbox"/>

Note: If mechanical interlock is selected, then a marine type auxiliary switch will be supplied. Marine auxiliary switch only operates in the connected position.

Type A - Indicate position of Gen. ACB

Left	Cent	Right
<input type="checkbox"/>	<input type="checkbox"/>	<input type="checkbox"/>

P1=  mm P2=  mm

All Types - Pitch 'P1' (1st & 2nd), 'P2' (2nd & 3rd)

Vertical Mechanical Interlock for two ACBs, one from two  
 Enter Vertical Pole Pitch 'P' Between ACBs

P=  mm

Door Interlock

Indicate type of drawout handle required Section 6 - External Accessories.

Cylinder lock (Lock in Off) and key  
 Cylinder lock (Lock in On) and key  
 Lock in Off Padlock Facility

<input type="checkbox"/>
<input type="checkbox"/>
<input type="checkbox"/>

Castell Fitting (Lock in Off) - Facility only  
 Castell Fitting (Lock in On) - Facility only  
 Castell Lock (Lock in Off) and Key (Factory fitted)  
 Castell Lock (Lock in On) and Key (Factory fitted)

<input type="checkbox"/>
<input type="checkbox"/>
<input type="checkbox"/>
<input type="checkbox"/>

Tick One Box

<input type="checkbox"/>	Enter Castell symbol required.
<input type="checkbox"/>	Enter Castell symbol required.

Chassis Castell (Lock in Isolate) - Facility only  
 Chassis Castell (Lock in Isolate) - Lock and Key (Factory fitted)

<input type="checkbox"/>
<input type="checkbox"/>

### 8. Earthing Devices: Tick required boxes.

Body (Portable Part)

Chassis (Permanent Part)

Earthing Device Note:

Not available with front connections.  
 Not recommended with a UVT, as manual disconnection is required.

### For Customer Notes or References.



# TERASAKI

*Innovators in Protection Technology*

## **TERASAKI ELECTRIC (EUROPE) LTD.**

80 Beardmore Way, Clydebank Industrial Estate,  
Clydebank, Glasgow, G81 4HT, Scotland (UK)  
Telephone: 44-141-941-1940  
Fax: 44-141-952-9246  
Email: [marketing@terasaki.co.uk](mailto:marketing@terasaki.co.uk)  
<http://www.terasaki.com>

## **TERASAKI MIDDLE EAST**

Saif Zone Q3-168, PO Box 120860  
Sharjah, UAE  
Telephone: 971-56-676-4825  
Fax: 976-655-78141  
Email: [middleeast@terasaki.co.uk](mailto:middleeast@terasaki.co.uk)  
<http://www.terasaki.com>

## **TERASAKI ELECTRIC (EUROPE) LTD. (FILIALE ITALIA)**

Via Ambrosoli, 4A-20053, Rodano, Milano, Italy  
Telephone: 39-02-92278300  
Fax: 39-02-92278320  
Email: [info@terasaki.it](mailto:info@terasaki.it)  
<http://www.terasaki.it>

## **TERASAKI ELECTRIC (EUROPE) LTD. (SUCURSAL EN ESPAÑA)**

Pol. Ind. Coll de la Manya, C/Cal Ros dels Ocells 5  
08403 Granollers, (Barcelona) España  
Telephone: 34-93-879-60-50  
Fax: 34-93-870-39-05  
Email: [terasaki@terasaki.es](mailto:terasaki@terasaki.es)  
<http://www.terasaki.es>

## **TERASAKI ELECTRIC (EUROPE) LTD. (FILIAL SVERIGE)**

Snickarvägen 2, SE-132 38 SALT SJÖ-BOO, Sweden  
Telephone: 46-8-556-282-30  
Fax: 46-8-556-282-39  
Email: [info@terasaki.se](mailto:info@terasaki.se)  
<http://www.terasaki.se>

## **TERASAKI CIRCUIT BREAKERS (S) PTD. LTD.**

17 Tuas Street, Singapore, 638454  
Telephone: 65-6744-9752  
Fax: 65-6748-7592  
Email: [tecs@pacific.net.sg](mailto:tecs@pacific.net.sg)

## **TERASAKI ELECTRIC CO., LTD.**

Head Office & Circuit Breaker Division  
6-13-47 Kamihigashi, Hirano-ku,  
Osaka 547-0002, Japan  
Telephone: 81-6-6791-2763  
Fax: 81-6-6791-2732  
Email: [int-sales@terasaki.co.jp](mailto:int-sales@terasaki.co.jp)  
<http://www.terasaki.co.jp>

## **TERASAKI ELECTRIC (M) SDN, BHD.**

Lot 3, Jalan 16/13D, 40000 Shah  
Alam, Selangor Darul Ehsan, Malaysia  
Telephone: 60-3-5549-3820  
Fax: 60-3-5549-3960  
Email: [terasaki@terasaki.com.my](mailto:terasaki@terasaki.com.my)

## **TERASAKI DO BRASIL LTDA.**

Rua Cordovil, 259-Parada De Lucas,  
21250-450, Rio De Janeiro-R.J., Brazil  
Telephone: 55-21-3301-9898  
Fax: 55-21-3301-9861  
Email: [terasaki@terasaki.com.br](mailto:terasaki@terasaki.com.br)  
<http://www.terasaki.com.br>

## **TERASAKI ELECTRIC (CHINA) LTD.**

72 Pacific Industrial Park, Xin Tang Zengcheng,  
Guangzhou 511340, China  
Telephone: 86-20-8270-8556  
Fax: 86-20-8270-8586  
Email: [terasaki@public.guangzhou.gd.cn](mailto:terasaki@public.guangzhou.gd.cn)

## **TERASAKI ELECTRIC GROUP SHANGHAI REPRESENTATIVE OFFICE**

Room No. 1405-6, Tomson Commercial  
Building, 710 Dong Fang Road, Pudong,  
Shanghai, 200122, China  
Telephone: 86-21-58201611  
Fax: 86-21-58201621  
Email: [terasaki@vip.163.com](mailto:terasaki@vip.163.com)



[www.terasaki.com](http://www.terasaki.com)

CAT REF. 21-I51EUa

©Copyright Terasaki Electric (Europe) Ltd 2021

Ratings and specifications are subject to change without notice.